

**JANOME**  
**REPORT**  
**2023**

# Corporate Philosophy

1. Janome aims to promote people's creativity and contribute to prosperity all over the world.

2. Janome works to improve society and culture by consistently providing valuable products and services.

Since our foundation in 1921 as Japan's first domestic sewing machine manufacturer, the Janome Group have been striving to solve social issues and contribute to the development of society through our business. For the further growth, we have formulated and implemented 'Reborn 2024', our new Mid-term Business Plan by utilizing the management resources and knowledge base that have been built and accumulated over the past 100 years.

The word 'Reborn' is selected to demonstrate our resolve not to hesitate to be reborn as New Janome, if that is what it takes to increase our corporate values.

With our plan's focus on sustainability, we are committed to continue increasing our corporate values further along the guidelines set forth in 'Reborn 2024', which should guide us through ever-changing business environment.



## CONTENTS

<b>Introduction</b>	
Corporate Philosophy	1
Contents	2
Message from the President	3
<b>Value Creation</b>	
History	9
Janome in your life	11
Corporate Value Creation Process	13
Source of Value Creation	15
<b>Vision &amp; Strategies</b>	
Mid-term Business Plan	19
Business Overview	23
Home Appliance Business	25
Industrial Equipment Business	28
IT Related Business	31
<b>Sustainability</b>	
Responding to Sustainability	33
Actions taken for Environment	35
Actions taken for Society	43
<b>Corporate Governance</b>	
Directors' Directory	47
Actions taken for CG	49
Message from an outside director	61
<b>News &amp; Topics</b>	
News & Topics	65
<b>Corporate Information</b>	
Financial Date	68
Corporate Date	74
Global Network	75

## Publisher's Note

'JANOME REPORT 2023' is a comprehensive summary of our activities for the stakeholders—users of our products, shareholders, investors and business partners—to understand Janome better.

We are committed to tackling social challenges of the times through our normal course of business, while continuously seeking to increase our corporate value.

### 【Reporting Period】

April 1st, 2022 to March 31st, 2023 (FY 2022)

\*includes certain activities and events after April 1st, 2023

### 【Issue Date (of the original version in Japanese)】

October 31st, 2023

### 【Scope of the Report】

JANOME Corporation and its domestic and overseas group companies

### 【Accounting Standard】

Japanese GAAP

### 【Reporting Vehicle】

Published on our website

<https://www.janome.co.jp/ir/> (Japanese website)

<https://www7.janome.co.jp/global/> (English website)

### Notes on the forecast

The descriptions in this report of the forecast for our future plans, targets and strategies are what we deem reasonable based upon currently available information and data, and may involve certain risks and uncertainties.

Please note that actual results and performances may differ due to various factors.

With the corporate philosophy above in mind, Janome has helped to develop and improve people's creativity and craftsman manufacturing by consistently providing valuable products and services. Janome will continue to contribute widely to society by business activities to fulfill our corporate social responsibilities.



Makoto Saito  
President

### President's Note on publishing JANOME REPORT 2023

In its quest to promote people's creativity and contribute to prosperity all over the world, Janome has, since inception, as inscribed in the corporate philosophy, endeavored to improve society and culture by consistently providing valuable products and services.

Let me assure you that we will not miss out on any opportunities to expand our corporate value by continuing to keep our close surveillance on constantly changing global situations surrounding our business.

I sincerely hope that this report will help you, the stakeholders of Janome group, understand who we really are and what we actually do.

### Looking back on the first year of 'Reborn 2024', our Mid-term Business Plan

'Reborn 2024', built on the basic principle of implementing sustainable management, developed to keep us on the sustainable growth track, is steadily driving Janome to complete the individual business plans developed by the three major business segments along the lines of the common goals of 'offering sustainable products to our target markets', 'reinforcing our supply chain' and 'proactive entry into the major markets'.

Fiscal year 2022, the first year of the Mid-term Business Plan, continued to deal a heavy blow on most of our business segments by such factors as extending delivery lead time of electric components including semiconductors, soaring parts prices and energy price hikes along with the unstable global circumstances which are as yet failing to show any signs of settlement. We have not, however, ceased to make a slow but steady step toward the completion of the 5 projects proposed in the 'Reborn 2024'. ※See page 21 for the outline of the 5 projects.

Bobinage network expansion project has identified 3 new locations in New York, Mizonokuchi and Kobe Motomachi, with each new outlet store actively spreading the message to the world that handcrafting with sewing machine is fun. Sewing shops and collaboration events orchestrated at each location received quite a few favorable reviews from the participating sewers. We will continue to test new ways to help you find sewing attractive at existing locations at the same time as identifying prospective location for new outlets. Visitors to Bobinage will be shown new in-store layout and displays filled with attempts to attract sewers by offering ways to entertain the visitors, who should feel rewarded by the kind of fun and joy that sewing experience have to offer. Bobinage will continue to identify ways to entertain wider variety of customers by trying new ways and means with their constant attention on the reviews from customer's on the fun and joy of sewing.

Three projects, namely In-house processing project, Hachioji headquarters renewal project and Made in Japan project while bearing different names, share a common goal. Participating members to the projects with diverse background and expertise are actively engaged in productive discussions on such topics as defining common concept for renewal areas amidst the steady expansion of production facilities.

### Environment surrounding Janome's businesses.

While Russian invasion into Ukraine remains unsolved for much longer than expected, inflationary pressures on a global scale coupled with the growing sentiment among major central banks are leaning more toward credit tightening. All of these factors are putting more strains on wholesale and consumer spending when the world is already plagued with such other concerns as political instability and slowdown in economy which are adding further uncertainties to already clouded future outlook. Janome could not escape this downward pressure, evidenced especially in the slowdown of sewing machine unit sales in the low-to-mid price range.

We are searching for ways to expand our profit on the domestic sewing machine sales structure built on the reorganization of school sale business in conjunction with the restructuring of door-to-door sales force, which has supported our domestic sewing machine sales for decades.

In top end sewing machine market, Continental M17, our new flagship model, was embraced with favorable review in North American as well as Australian markets. Success of the top end model also directed the buyer's interest to the other existing Janome models, leading the customers to rediscover Janome's product line, resulting in good sales of high value added products.

Lesson learned from this chain of events is that stellar success of the top end catches great amount of attention to Janome brand itself, which has a ripple effect to the other high value products. We will continue to focus on developing and introducing high value added products and reap the benefit of higher brand value by selling more high value added models.

Low-end model sales fared well in proportion to the market size and price point in Asian region including India, one of the critical market we focus our management resources.

We will concentrate our focus to speed up our current effort to entice our customers to replace light alloy sewing machines with cast iron models, which should increase the sales of Janome branded products.



While we expect that it would still take long before things get back to normal, we are seeing signs of gradual recovery in our customer's order inquiry to our products, thereby boosting domestic production sectors as evidenced in improving capital investment environment. Automobile industry, our major market, is going through enormous innovation phase of dynamic changes driven by the further development of electric vehicles. Janome will proactively increase opportunities to exhibit its industrial equipment business at major exhibitions and local events of various industries, demonstrating how it may assist our customer's business executions so we can establish diverse sales network, which will assist us to capture divers business opportunities in new energy, environment and medical industries to name a few.

Immediate challenge facing IT-related business is to stay on top of the immediately current flow of IT industry, which never ceases to change. 3 steps to stay in the game is (1) to steadily complete what we can do now, (2) to forecast what will come next, both resulting in accumulating success and achievement experiences which will present you with limitless opportunities of attempting to forecast future technologies. That is one of the reasons to justify such management strategy as M&A.

Rich expertise and know-how Janome has accumulated in so many actual system integrations successfully completed to our customers specification will also be employed in identifying and winning new customers, at the same time as we reinforce our quality control as well as fine tune the Digital Transformation of the Janome Group itself.

### Sustainability-in managing both company and the products

We live in a time when new buzz words like 'sustainability' and 'green transformation' come and go one after another in the context of environmental considerations.

What I see as the challenge to the corporate management is to stay open to new ideas and remain unbiased on new developments of the idea until you make an objective judgment and follow through on that. 'The Janome Group is resolved to conduct its corporate activities while paying appropriate attention to conserve the natural environment as well as to contribute to sustainable development of society, based on the recognition that one of the most significant universal challenges to mankind is to conserve the global environment where man lives in harmony with nature'.

This is the backbone against which Janome endeavors to conduct sustainable management, which does not preclude us from reviewing and revising the plans and strategies as needed, when new development arises demanding revisions to the plans and strategies. It will certainly take a while until Sustainable management evidences palpable results. Sustainability Advancement Committee will be the centerpiece of the challenge to create structure and environment where each employee will learn how to connect individual mindset and behavior at work with sustainability management concepts.

With its original functions and features of re-make and reuse, sewing machine directly satisfies ethical consumption needs on top of he fact that sewing machines are inherently sustainable and environmentally friendly.

In the era when contributions to conserve environment directly affect consumer behavior, sustainable nature of sewing machine should be capitalized in our presentation of sewing machine especially to younger generations who have had little exposure to the machine, may drive rapid expansion of sewing machine market. On top of the high quality and high value addition to the sewing machine for longer service to our customers, Janome pays tremendous attention to detail on the exterior look of sewing machine to blend into the room interior so that it remains out of the box, ready to be used any time as needed. Epolku, Epolku OVI and SEWLA may well be front runners of sustainable models, retaining user friendly ease of use renowned for Janome since inception as well as blending well with the modern housing specification including the interior fixture and furniture. 'I didn't know there are such cute models available now' and 'They can be perfect match with the interior element in my room' are among many reviews from the customers who visited Bobinage events and workshops at major retail outlets. Those rewarding words, I believe, will certainly drive Janome on its sustainable growth path.

Industrial Equipment received not a few frim inquiries at some exhibitions where we promoted 'Servo Press', electro press with cleaner specification aimed at Carbon Neutral Society, as well as 'Press Fit Device', environmentally friendly implementation.

JP Series 5, our servo press, successfully obtained MF Eco Machine Certification, giving us assurance and confidence that we are progressing on the right track of realizing sustainability management.

Desk top robots made entry to medical industries on top of the existing manufacturing equipment arena, leading to increase medical opportunities for wider patient base by interfacing desk top robots and 3D printers. We expect further usage beyond medical treatment scenes, so that industrial equipment value will expand beyond factory floor and operation room with continued focus on originating products promoting to decrease environmental load in terms of environmental contribution.

### Sustainability-Human asset<sup>※</sup> development and social contribution

In its quest to establish sustainable corporate management, Janome has integrated its management resources to promote and progress (1) recruiting and developing human asset, (2) creating better working environment, (3) female career advancement and (4) human rights awareness. It is one of my responsibilities to create atmosphere (circumstance) at every work place in Janome to understand and respect fellow worker's individual circumstance and to accommodate for his or her absence due to inevitable needs for life events or anniversary, so that all the employees feel comfortable when he needs to exercise his options to take for example maternity leaves. Any worker doesn't have to feel threatened of unfair treatment when he or she faced with such life events as maternity and/or nursing care leave.





I expect every one of my employees to be aware of and show willingness to accommodate for others involved in major life events requiring long leaves of absence, so that no one should feel threatened to be punished or treated unfairly upon their return to the original work place.

It is one of the management responsibilities to foster understanding of and considerations for those taking such life event as leaves of absence.

For female career development, the prime target is set by the fiscal year end 2025 to raise the ratio of female managers at Head Office to 20% among all the managers. Target is not deemed successfully reached if it's reached without substance. Appointing female directors and managers for the sake of merely satisfying the 20% target does not help you getting closer to realize sustainable growth. Exaggerated focus on being female may alienate other minority groups. We should use face to face contact opportunities with employees more fully to understand what issues and challenges are facing them, including how to maintain work life balances.

※'human asset' is Janome's original term for human resources, as Janome treat them as one of the major assets of the company

### Closing remark

It is indispensable to amass the abilities and contribution of each and every human asset that Janome has to reach the various targets we set out for the budget. We may not be able to honor the lofty target budget set out as the management goals, unless the maximum ability is contributed from each and every employee of Janome. First step we take is to share information and listen closely to each employee and deal with the issues for solution one by one. We are resuming group seminars and discussion sessions for groups of employees which had, until New Corona Virus pandemic, the track record of offering successful opportunities where employees feel free to exchange their ideas and views.

Janome management is resolved to cope with the issues and to present the company in good shape by the end of the 1<sup>st</sup> half year of Reborn 2024 with the contribution from each and every employee. I would sincerely like to ask you all for your continued guidance and support for the Janome Group.

Janome management is resolved to cope with the issues and to present the company in good shape by the end of the 1<sup>st</sup> half year of Reborn 2024 with the contribution from each and every employee. I would sincerely like to ask you all for your continued guidance and support for the Janome Group.



▶Mid-term Business Plan (See page19)



Janome started with the first domestically produced sewing machine and gradually expanded its business by applying the technologies developed for sewing machine production to other businesses such as industrial equipment. Having been through our many ups and downs path, we will pass our proud possession of technological buildup and sincere attitude of 'craftsman manufacturing to the future generations and will continue its challenge aiming to promote people's creativity and contribute to prosperity all over the world.

### Founding

Yosaku Ose, one of the founders started in 1921 Pine Sewing Machine Factory predecessor of Janome, aiming to domestically produce the machine at affordable prices. Successful launch of the 1st domestically made machine marked our first step as the sewing machine manufacturer. Originating monthly subscription sale with pre-order and organizing special sales force boosted the sale and leading us to build in 1936 Koganei Factory, the first mass production factory in Japan. We changed the company name in 1954 to 'Janome Sewing Machine Manufacturing Co., Ltd.' to articulately represent our manufacturing forte.

### Time of quantum leap

Acquisition of the major US sewing machine maker, New Home Sewing, epitomized Janome's aggressive expansion into global consumer markets during Japan's rapid economic growth era. Janome established its overseas production hub in Taiwan and in 1964 Research and Development Center in Hachioji Tokyo, where new applications and technology development have been sought, bringing many new products to market. Janome was first in taking on optimizing administrative work, span off in 1970 its computer business function to set up Janome Computer Center, now known as Janome Credia, who aims now to expand processing outsourced admiring work by using main-frame computers and high-speed OCR.

### Sewing technology application leading to diversification

Memoria, launched in 1979, the first computerized model developed in Japan rocked the home sewing machine industry to the great era of renovation. Janome applied production technologies developed for sewing machines to industrial equipment. Electro press (servo press), JP-20, developed in 1984, is powered by electricity, which was a breakthrough technology for press industry. With this, Janome started its challenge to be a major player in industrial equipment industry. Janome also ventured seriously into industries other than sewing machine, including 24 hour hot bath system 'Yu-meijin' developed in-house. Production facility was reinforced by Thai Factory, built to accommodate soaring demand from growing global sales of sewing machine.

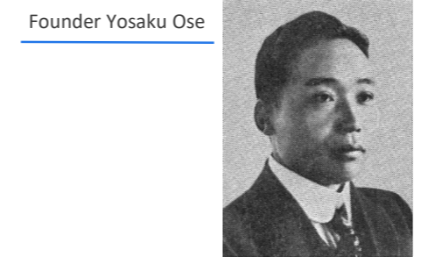

### Management system restructuring

Janome has progressed on fundamental restructure of its management system to overcome the management crisis in 1990's, when a speculative investor group manipulated our stock price by substantial stock holding. Our effort was culminated in 2009, when the head office functions were moved from Kyobashi in central Tokyo area to Hachioji so that all the functions are consolidated under one roof. Communication and cooperation among departments namely planning, R&D, production, sales and sales follow-up improved substantially and response to customer requests and needs are completed without delay.

### Contribution to rich & creative craftsmanship manufacturing

Sewing machine performs different functions over time from an appliance to help save household expenditure to an instrument to assist a user to realize his or her diverse personal interest. Janome, known for its proven quality, continued its challenge to develop sewing machines that stimulate user's creative aspirations and comes with ease of use and high quality. Result of this 100 years of challenge was culminated(exemplified) in the recent flagship model, Continental M17, launched in April 2022 for overseas markets. Industrial equipment business will continue its growth as a company to support craftsmanship manufacturing who listen to the real voice of the production lines to accommodate the rising demands for precision and information equipment that require exacting accuracy and clean operational environment.

### Beyond 100th Anniversary

We changed our corporate name from Janome Sewing Machine Co., Ltd to Janome Corporation to coincide with the milestone 100th year since founding in October 2021. We also developed for the occasion 'Reborn 2024', New Mid-term Business Plan, as yet another transit point of our flight for the next 100 years as 'New Janome'. Janome has endeavored to fully comply with corporate governance by such measures as transition to Company with Audit and Supervisory Committee in its pursuit of elevating authority and supervisory capacity of the Board of Directors. 'Reborn 2024' stipulates as Janome's basic policy to continue promoting sustainable management by realizing sustainable society and sustainable growth of Janome's business. Janome will engage all its resources to continue its sustainable growth.

▶Mid-term Business Plan 'Reborn 2024' See page 19

1921 1960 1980 1990 2010 2020~





## Sewing machine project samples created to enrich your life

Tapestry created with Digitizer, embroidery data digitizing software

Quilt project

Embroidery couching with yarn

Tote bag embroidered with yarn

beading foot

Hat decorated with beads, sewn with beading foot

Dress

Lace embroidery

Accessories made with lace embroideries

Cushion decorated with applique

Pot cover

Book cover

## Robots & Servo Presses Serving at the Production Site

Robot Application Servo Press Application

**AUTOMOBILE**

- Car Navigation/Audio, Airbag Sensor: Dispensing, Soldering, Depaneling
- Airbag Sensor: Swaging
- Gear Box, Bearings: Press Fitting
- Engine, Cover: Thermal Pressure Welding
- Wire Harness, Connectors: Soldering
- Built-in Camera: Dispensing, Soldering, Depaneling
- Seatbelts: Swaging, Bending
- EV Motor: Swaging, Press Fitting
- EV Inverter Board: Dispensing, Screw Tightening, Depaneling
- EV Battery: Compressing, Cutting, Bending, Swaging
- ABS Hydraulic Circuit, ABS Sensor: Press Fitting, Sealing
- Dispensing, Plasma Irradiation

**SMART PHONES**

- Body Assembly: Screw Tightening
- Vibration Motor: Swaging, Press Fitting
- Miniature Screw Tightening: Screw Tightening
- Battery Case: Dispensing
- Camera Module: Dispensing
- Organic EL: Dispensing
- Pressure Bonding
- Button Testing: Inspection
- Speaker, Earphone: Dispensing, Soldering
- Forming

**PRINTED CIRCUIT BOARD**

- Sealant: Dispensing
- Miniature Screw Tightening: Screw Tightening
- Lead Frames: Cutting, Bending, Swaging
- Connectors: Press Fitting
- Plasma Irradiation



# Value Creation Process at Janome

In its quest to realize the corporate philosophy, the driving force of all the corporate activities, the Janome Group has offered rich and creative values to all the stakeholders by delivering the highest quality products and services supported by its competitive strengths of 'Human Assets', 'Technological Strength', 'Brand', 'Global Network' and 'Financial Foundation'. We will contribute to the realization of sustainable society by responding to various challenges that society will face, thereby expanding our corporate value.

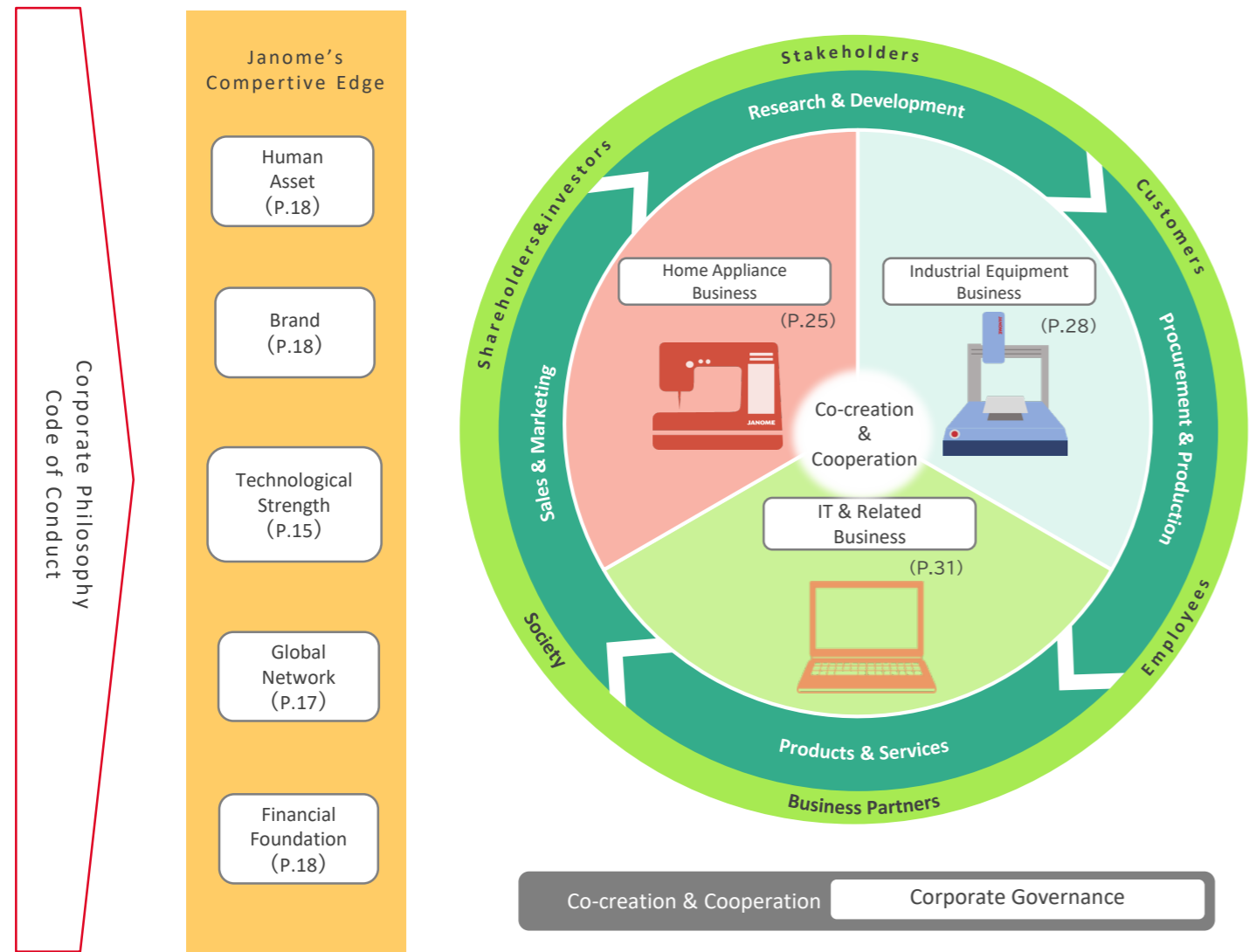

### Key Performance Indicators for FYE 2025.3

Sale Amount	48,000 Mill. Yen
Operating Income ratio	10.4%
ROE	10.0%

▶(See page21)

### Measures to Solve Materiality (important material issues)

- E**nvironment
  - Considerations for Environmental Load
  - Environmental Protection
  - Response to Natural Disasters
- S**ocial
  - Sustainable Economic Growth
  - Rewarding Workplace
  - Respect for Human Rights
  - Social Welfare Activities
- G**overnance
  - Reinforcement of Governance
  - Peace and fairness

▶(See page34)

**Janome's Accumulated Strength**

**Production of its 75 millionth sewing machine**

August 31, 2023, Janome celebrated the production of its 75 millionth sewing machine, and the new model "HORIZON Memory Craft 9480QC PROFESSIONAL" (released on August 14, 2023) launched for overseas became the commemorative sewing machine for the achievement. We were the first in the world to achieve this feat as a result of our business developed into an integrated handles everything from planning, development, production through to sales and service to meet the needs of our customers.

— Janome's Competitive Edge —

# Proven technical capabilities support manufacturing culture

Janome established the world's first general research center for sewing machines in 1964, the 39th year of Showa era, and has since pursued its research and development of high quality and high value added products as a leading household sewing machine maker.

The industrial equipment segment of Janome's business, initiated by applying technological strengths nurtured over the history of successful household sewing machine production, expanded its technological reach from desktop robots into high-spec SCARA robots and servo presses, and has developed an industry customer base ranging from automobile and smart phone related precision mechanical equipment manufacturers to research institutes and universities, as well as the food industry.

Janome products, widely supported for having the 'Janome standard of quality' by many customers around the world, are produced in three factories, the Tokyo Factory, located within Janome Headquarters in Hachioji, Tokyo, Taiwan and Thailand.

Tokyo, as Mother factory, produces top-end household sewing machines and industrial equipment products. It also strictly monitors and controls the production progress in other factories so that all the factories maintain optimal production allocation. Manufacturing technological expertise amassed over the long history of the Tokyo factory have introduced to the Taiwan and the Thailand factories.

In this rapidly changing modern society, it is vitally important to accurately capture and whenever possible predict in advance, customer needs. We are taking every step to expedite the development and production cycles without compromising high quality standards so that we bring to the market those products that will satisfy our customers' needs.

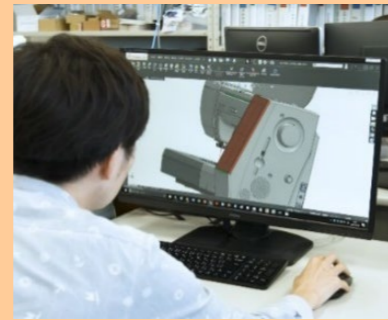

### 3 pillars to support excellent Janome quality

#### •Product development format

Detailed standards are designated for individual product price points which work as guidelines for selecting optimal design and components, guaranteeing products with extensive capabilities, excellent durability and stable quality.

#### •Stable quality parts

Establishing a manufacturing hub in Taiwan in 1960's ahead of the competition, Janome has built close ties with key local parts suppliers, who enable Janome to maintain its attention to detail of each and every part selected. Automated production has been introduced for some internal part production as one step to improve the efficiency of the production system.

#### •Production structure

Manufacturing expertise and technological edges, amassed as the domestic pioneer household sewing machine maker, have been implanted and expanded on in overseas factories. An engineer exchange program is in place between Tokyo and Taiwan that has worked to improve the engineering expertise of both the operations.

— Janome's Competitive Edge —

## Global Production Allocation



#### Tokyo Factory: 'Mother Factory' Production Management Division

Governs overall production by monitoring the utilization rate, operational progress and profitability of each factory. It is an integral fortress of quality assurance, following up on updated information regarding various safety regulations and monitoring compliance therewith including performing inspections to protect Janome's high quality standards.

#### Challenges & Action Plans

Renovate production control system to increase output as well as to reduce time to delivery of industrial equipment, accommodate in-house fabrication and high-mix small lot production, Promote 5S Activities, Promote succession of technology and prevent potential loss of production expertise contingently triggered by production relocation to overseas factories



#### Janome Taiwan: 'Main Factory'

Compliments Tokyo Factory with the function of production technology division by facilitating minor changes of certain models so as to expedite the new product development process as well as to reduce development cost. It also integrates painting divisions and performs key functions as parts supply center to all the factories.

#### Challenges & Action Plans

Review production line configuration, promote further automation of operations including in-house parts production department, computerize information control such as 'tact time', or cycle time to reduce costs, Improve quality and production efficiency



#### Janome Thailand Factory: 'Strategic Factory'

Structured to produce affordably priced models efficiently to cope with the exacting price competition

#### Challenges & Action Plans

Promote production leveling to streamline output quantity and labor management efficiency

## Technological edge and characteristics of Janome products

### Home Appliance Products

New element development in both structural and electrical areas is focused on ease of use that has led us to develop the breakthrough technologies for sewing machines substantially improving efficiency and ease for customers to create projects with such functions as Wi-Fi communication, editable embroidery design application and stitch regulation function, which enables equal stitching irrespective of fabric travelling speed in free motion sewing

### Industrial Equipment Products

- ①Vocal data entry saves time to kick start the operation.
- ②Products with environmental considerations by noise reduction and electricity saving functions,
- ③Improving operational efficiency at the production site by products with high level of speed, accuracy and payload capacity,
- ④Monitoring through network equipment during operation to detect errors.

#### Challenges & Action Plans

#### •Construct next generation development platform

Reduce development lead time and structure the foundation to tailor products more closely in line with customer requests

#### •Educate and train engineers

Develop human asset aimed at improving overall technological strength, pass on the existing technological edges and expertise to future generations, pass on the existing technological edges and expertise to future generations, expand employee reward system for voluntarily obtained licenses and qualifications

#### •Develop new technology

Utilize Artificial Intelligence and IoT (Internet of Things), organize a project team and elaborate at workshops to develop breakthrough technologies that will capture the potential market demand which has not yet materialized, organize and conduct seminars and voluntary learning sessions on new technologies

▶Actions to develop environmentally conscious products(See P37)

## Development/Production Flow Chart

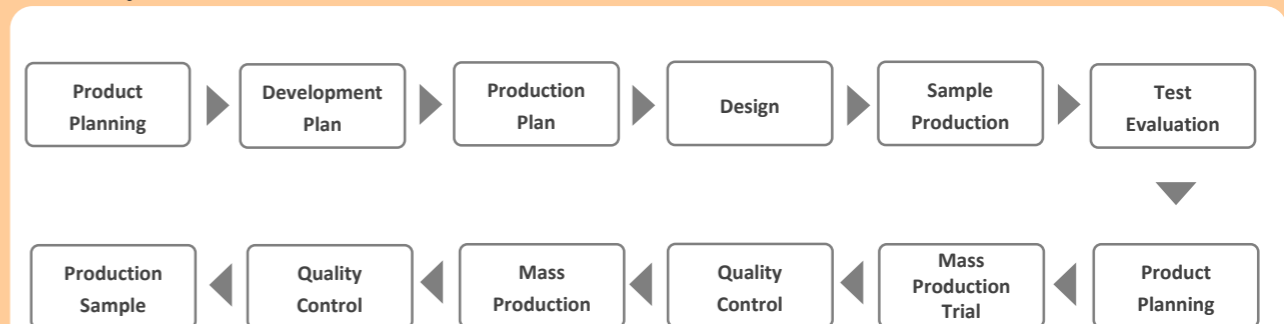



— Janome's Competitive Edge —

# Global Network

Janome has built a global distribution network so it can swiftly respond to wide ranging needs of the Janome users in the various markets around the world. 17 overseas sales units, firmly supported by the Head Office Division—work closely together to supply our products that satisfy our customer's needs.

Household sewing machine sales subsidiaries constitute a major engine of the Janome Group's overseas sales activities, which are aligned along the area marketing strategy in major markets of North America, where Janome America, Inc. has been a force since 1960's, Europe and Oceania.

Industrial equipment sales subsidiaries entered the markets dominated by automobile related industries, as JIE America entered Chicago in 2007 at the heart of American manufacturing industries, and are engaged in sales development activities, followed up with after sales service, by demonstrating how useful and original our equipment is.

Janome manufactures the products it sells in 3 factories in Tokyo, Taiwan and Thailand, each one of whom is engaged in its inherent functions, however they are structured to compliment each other in extraordinary situations like natural disaster.

▶ Proven technical capabilities support manufacturing culture (See page15)



▶ Global Network (See page75)

※ JIE stands for Janome Industrial Equipment.

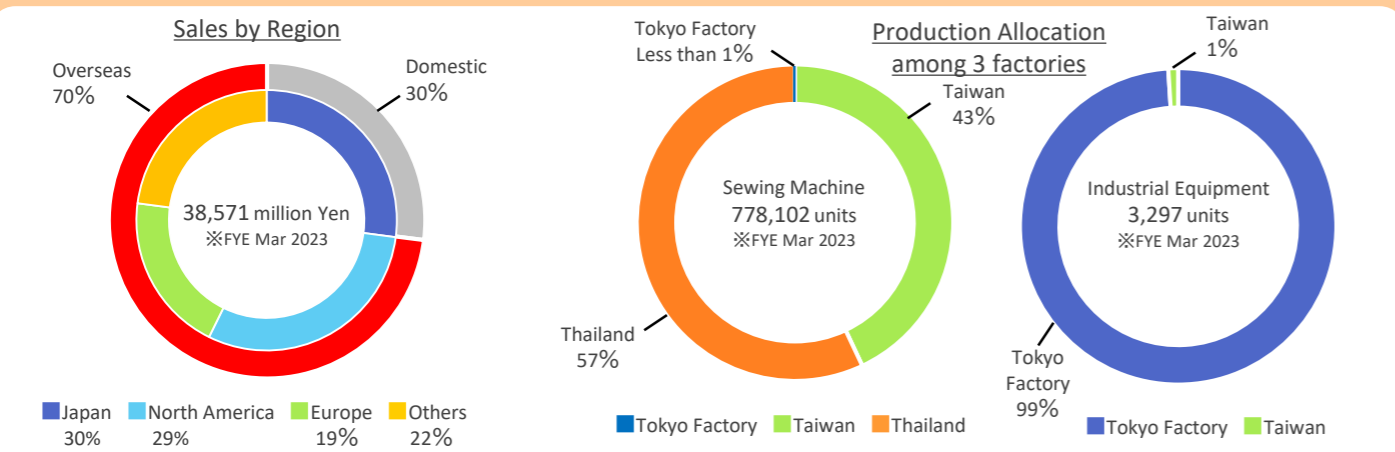

— Janome's Competitive Edge —

# Janome supported by diverse human assets

The Janome Group regards its employees with the highest esteem of all its assets. Measures have been taken to seek the best work life balance and to reach the state of well being by introducing work place reforms. Abundant educational options are in place for employees to obtain and improve various skills. Janome is also keeping its door open for human assets with diverse background as foreigners, mid-career recruits and persons with disabilities who would bring diverse cultures and different values which should contribute to create new innovations.

▶ Actions taken for Human Resource (See page43)

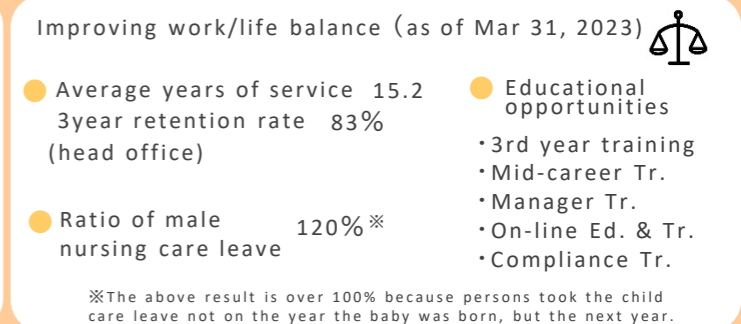
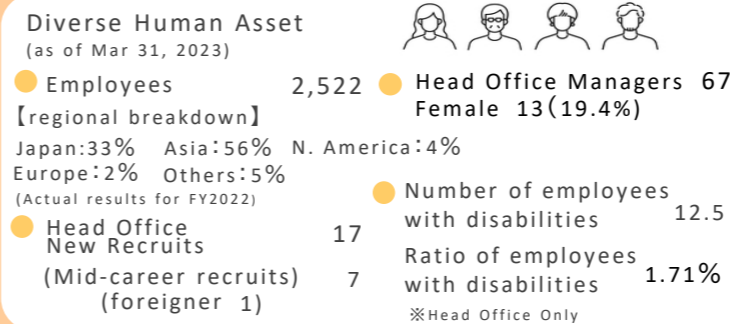

# Brand with trusted quality and reliability

The Janome Group has found many heavy users of its products around the world who value its high specifications and uncompromising quality underwritten with proven technologies amassed over the years of experience. Janome brand is now widely identified with trusted quality and ease of use and is embraced with excellent reputation, giving household sewing machine top share in Japan and substantial share in overseas market. Desk top robots and servo presses also enjoy leading share in each segment.

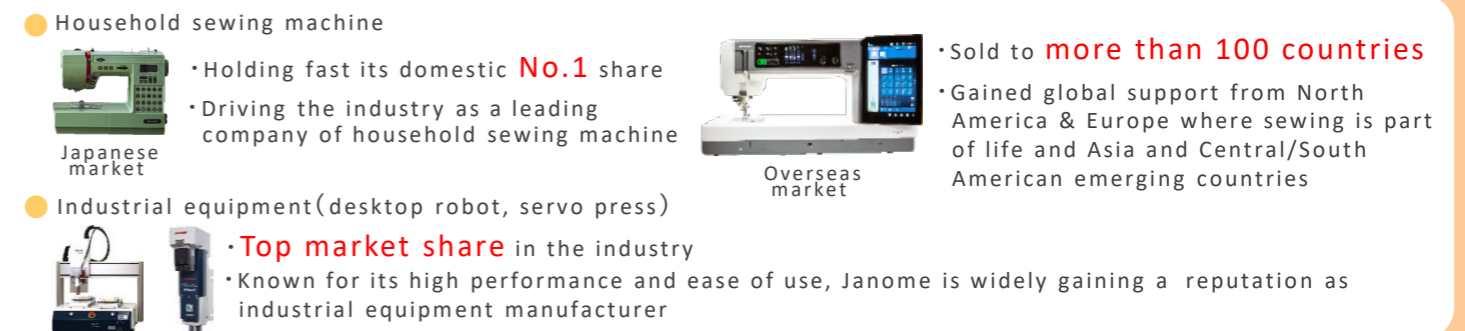

# Financial foundation

Financial strategy of the Group aims to both maintain financial stability and to increase capital efficiency by maintaining the sound capital structure with effective use of interest-bearing debt. Equity ratio has improved by reducing liabilities with debt retirement and is maintained at relatively sound level. Individuals hold the majority of our share. We will continue to improve financial stability so that long term relationship with the shareholders is maintained.

**Equity ratio**

FYE2018	FYE2019	FYE2020	FYE2021	FYE2022
49.4%	49.7%	54.7%	59.5%	63.8%

Number of shareholders (as of March 31, 2023)

17,685

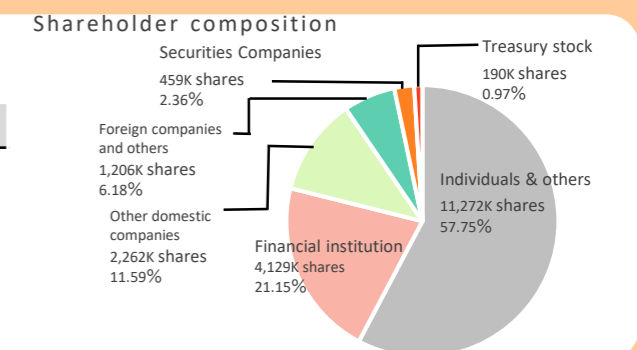



The Mid-term Business Plan started from 2022 'Reborn 2024-SUSTAINABLE GROWTH for the NEXT 100 YEARS' was developed with various measures in accordance with the basic policy "Move forward with sustainable management to drive sustainable growth of the company".

It is made with a determination of New Janome to venture a new step into the next 100 years to expand its corporate value further, at this historical its corporate name to Janome Corporation and its financial foundation is showing certain signs of improvement.

**Basic Policy** Move forward with sustainable management to drive sustainable growth of the company

- ✓ **Evolve with Janome's DNA (flexibility, willingness to embrace challenges, and pride in our products) firmly in place.**
  - Expanding business overseas to capture the untapped market.
  - Diversified business to Industrial Equipment and IT based on knowledge and technology accumulated by various daily operations of manufacturing, selling and distributing sewing machines.
- ✓ **Maximize Janome's resources (see below for main resources/strengths)**
  - The corporation which maintains all channels - from R&D, production and sales / distribution.
  - Centralized facilities: R&D, mother Factory and headquarters are all located at the same site in Hachioji, Japan.
  - Being a leading company in home-use sewing machine industry.
  - 3 different business divisions (Sewing Machines, Industrial Equipment, IT) can have synergy benefit for each division's growth.
- **Preserve the culture and value of the sewing machine**
- **Expand the Industrial Equipment business**
- **More focus on IT business through subsidiary**
- **Start 5 projects which cross over multiple divisions**
- **Sustainable management**

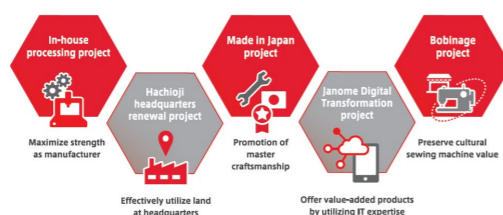

Seeking corporate value expansion at the same time as realization of sustainable society

JANOME 2021  
Navigation for the Future  
(FY2019~FY2021)



**Aim at sustainable growth for the next 100 years**

Transit point

**Increase our corporate value**

**High Revenue model management**

**Common policies**

- Offering sustainable products
- Strengthen supply chain
- Actively act and gain ground in important markets

**Home appliance business**

- Maintain the value of sewing culture and sewing machines, re-evaluated by stay-at-home demand. Also lead the market as a leading company in the industry.
- Improve Janome global brand recognition
- Increase sales to make up for the loss of Russian sales

**Industrial equipment business**

- Move and act aggressively to make this the second pillar of business at Janome, including possible M&A
- Staffing and expansion for important markets

**IT & related businesses**

- Drive DX strategy in the Janome Group and expand external sales of products and services based on this experience
- Establish strong position as a partner who can solve tasks together with customers

### Progress to date on 5 projects

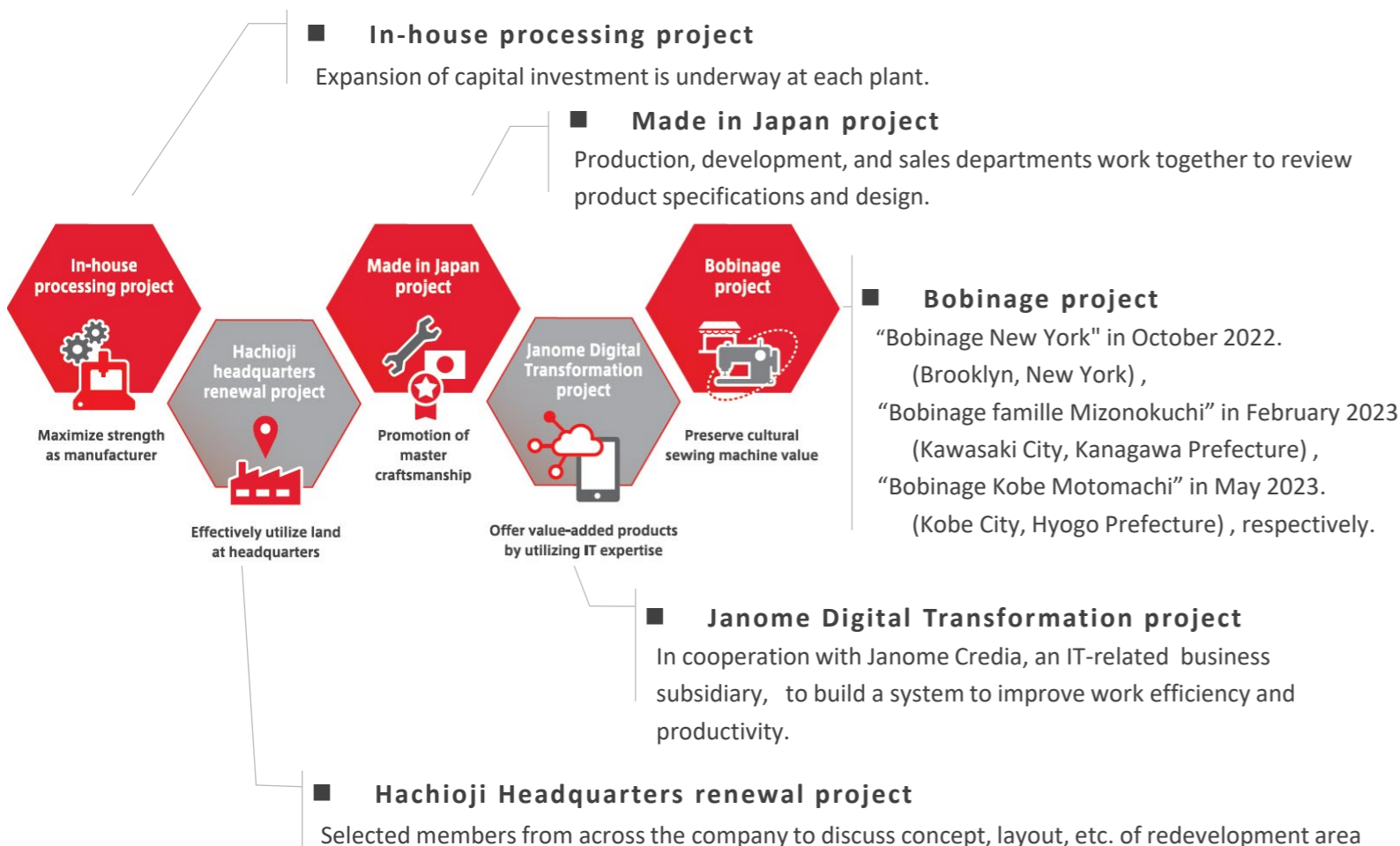

### Key Performance Indicators (KPI)

(Unit: 1Mill Yen)

	FYE 2022.3 Result	FYE 2023.3 Result	FYE 2024.3 Forecast	FYE 2025.3 (Goal)
Sales Amount	42,916	38,571	40,000	<b>48,000</b>
Operating Income	3,659	2,120	2,500	<b>5,000</b>
【Percentage】	8.5%	5.5%	6.3%	<b>10.4%</b>
Ordinary Profit	3,824	2,400	2,500	<b>4,900</b>
【Percentage】	8.9%	6.2%	6.3%	<b>10.2%</b>
ROE	8.2%	△1.2%	—	<b>10.0%</b>

#### Target shareholder return policy

Under "Reborn 2024," we aim to pay stable and continuous dividends, with a target total return ratio of 30% in the medium to long term.  
In order to increase the level of shareholder returns and improve capital efficiency, the Company began repurchasing its own shares on August 10, 2023. (1,000,000 shares/700 million yen (maximum)) Regarding dividends, we will strive to return profits to shareholders by steadily and continuously increasing dividends, with a minimum target of an annual dividend of 25 yen per share.

### Continued Listing Criteria (Prime Market)

Current Conditions (FYE 2023.3)	Listing Maintenance Criteria	Our Situation	Improvement Period Schedules
Number of Shareholders	800	<b>15,903</b>	
Tradable Shares (unit)	20,000 units or more	<b>157,776</b>	
<b>Tradable Share Market Capitalization</b>	JPY 10 billion or more	<b>96.5</b>	By the end of March 2025 in accordance with the last year of the Mid-Term Business Plan "Reborn 2024"
Tradable Share Ratio	35.0% or higher	<b>80.8</b>	
Amount of Net Assets	Be a positive figure	<b>Positive Figure</b>	

※The above is calculated on the information of distribution of the Company's share certificates, etc., available to Tokyo Stock Exchange, Inc. as of the base date.  
As of March 31, 2023, status of the Company's compliance with the criteria for maintaining its listing on the Prime Market was as shown in the table above, and it did not meet the requirement regarding Tradable Share Market Capitalization. The components are "Stock Price" and "Number of Tradable Shares" and the main reason for the violation is the "Weak Stock Price". In order to improve the "market capitalization of tradable shares," we will achieve sustainable management through business execution based on the Mid-term business plan by continuously expanding business performance, returning profits to shareholders, strengthening corporate governance, and further promoting IR activities, aiming to comply with the criteria for maintaining listing.

#### Challenges

##### Market valuation declined due to shrinking business performance (sales and profits)

- Slowdown in the global economy against a backdrop of tight monetary policies and political instability in various countries
- Slowdown in the sewing machine market due to settling demand for staying at home, etc.
- Sluggish growth in the industrial equipment business due to parts procurement difficulties and dependence on specific markets and industries



#### Efforts to Address the Challenges

- ① Improve business performance by implementing measures in each business set forth in the Mid-term business plan**
  - 【Home Appliance Business】
    - Secure profits through high value-added models mainly in the North American market
    - Sales increase due to aggressive sales of low- and mid-priced models in Asia and other emerging countries
    - Aggressively stimulate demand through participation in exhibitions, workshops, SNS, etc. in Japan
  - 【Industrial Equipment Business】
    - Focus on environmentally friendly product approach and development of new markets and applications, including the medical field
  - 【IT & Related Businesses】
    - Supporting DX promotion of domestic businesses as a problem-solving partner for "DX" that is close to customers with the know-how cultivated through in-house development.
- ② Shareholder Returns**
  - Direct returns to shareholders through stable dividends while aiming to enhance the amount of dividends
  - Implement share buybacks in consideration of the business environment and other factors, and strive to improve ROE and PER to return profits to shareholders
- ③ Strengthen corporate governance and enhance IR activities**
  - Gradual reduction of stock holdings for policy holding purposes
  - With our individual shareholders, who account for more than 95% of our shareholders and our main customers of home-use sewing machines, we will proactively develop not only IR information but also product information, business activities, social contribution activities, and initiatives that lead to sustainability in the "JANOME REPORT" and other publications to help them understand our initiatives.

Our company has three business segments: “Home Appliance Business” offering home-use sewing machines; “Industrial Equipment Business” offering industrial equipment including servo presses and desktop robots; and “IT Related and Other Businesses”.

### Home Appliance Business

As a leading home-use sewing machine company, our products are being sold in more than 100 countries beyond the Japanese domestic market and are supporting sewing life with a variety of product lines to meet a range of needs and applications.

In order to offer even more attractive products, we will continue to “develop sewing machines with concepts” and accelerate the speed of launching value-added and high-function sewing machines in the market.

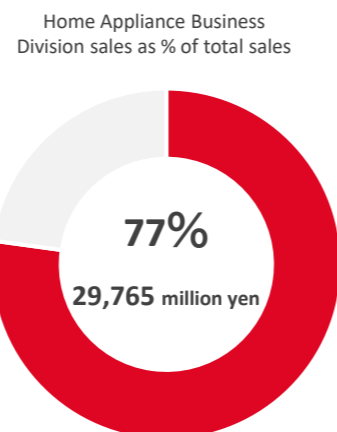

#### Main Products



Sewing machine for quilting



Embroidery/Sewing



Computerized sewing machine



Professional sewing



Overlock



Professional embroidery

#### ◆ Overseas Sales (See page26)

Our products are being sold in more than 100 countries through subsidiaries and distributors located in each market. We offer safe and reliable products and services which suit the individual needs of each market through the active deployment of area marketing.

#### ◆ Domestic Sales (See page27)

As a leading home-use sewing machine company, while always aiming to have the number 1 share of the Japanese market, we have strived to support and promote sewing culture. At the end of March 2023, we withdrew from the direct sales business through the Janome direct branches nationwide, in a shift from the sales system we have used to date.

In addition to strengthening sales through distributors, we are expanding efforts to promote sewing and give people the opportunity to use sewing machines. These efforts include establishing the sewing shop “Bobinage” and enhancing support for sewing in schools and educational facilities. While responding flexibly to the changing times, we will continue to introduce customers to the joy of sewing and making things with sewing machines.

### Industrial Equipment Business

Janome continues to steadily expand the second pillar of our business, industrial equipment. Built upon high precision position control technology gained through Janome’s long history of home-use sewing machine development, the Industrial Equipment Division actively develops, manufactures and sells original industrial equipment and related parts.

Janome Group also manufactures and sells precision die cast and plaster cast parts and parts feeders (devices which deliver parts such as screws, etc. for use in assembly)

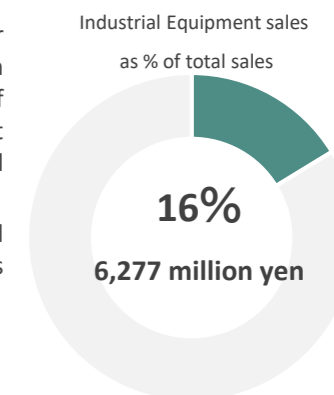

#### ◆ Robots & Servo Presses (See page28)

Robots and servo presses are two of our main industrial equipment product lines, serving customers worldwide in manufacturing sectors such as IT, electronics, automotive parts production and more. Domestic branches in Tokyo, Nagoya, Osaka, Fukuoka and Yamagata overseas subsidiaries in the U.S., Germany, China, Taiwan and Mexico comprehensively support Janome’s industrial equipment sales and customer service activities.

#### Main Products



Electro Press  
(Servo Press)



Desktop Robot



Cartesian Robot



SCARA Robot

#### ◆ Die Cast Products (See page30)

Seeking a way to reduce the weight of our sewing machines by expanding upon conventional die cast technology, Janome Diecasting went even further, currently serving in various fields including automotive, industrial robotics, precision instruments and medical equipment.

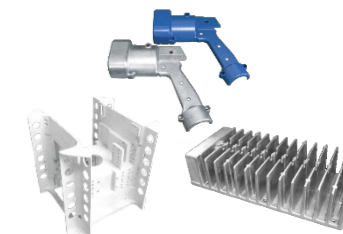

### IT & Related Business

In the IT business, Janome offers IT software development data processing and system operation management outsourcing services. Based on our in-house development of manufacturer-oriented systems for order talking, product management, and accounting, we work in various fields as a leader of the new era by utilizing our accumulated system development technology and know-how for the next-generation information society. Today, we provide total support for our clients' business operations through information processing services and outsourcing services, as well as system and software development in a wide range of industries and business categories, including distribution, construction, telecommunications, and manufacturing. We aim to provide speedy, streamlined services in response to changes in the environment and corporate needs in today's rapidly evolving IT society. (Please see p.31)

IT related Business sales  
as % of total sales

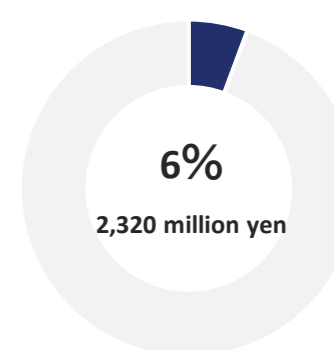





**Overseas: Expanding its global reach as a leading household sewing machine company**

**Business Environment: Opportunities and Risks**

- Rebound in demand for home-use sewing machines, which was boosted by the COVID-19 pandemic
- Impact of the protracted situation in Ukraine on the economies of neighboring countries and loss of sales to Russia due to economic sanctions
- Soaring prices including energy prices, and a sense of uncertainty about the future
- Approaching the sewing machine market with a view to expanding its base



**Summary of FYE March 2023 results**

In the household equipment business, the flagship Continental M17 model for overseas markets was well received, particularly in North America and Oceania, and sales especially of high-value-added products, including this model, grew and contributed to profits. In Asia too, sales of sewing machines fared well. However, due to the still unresolved situation in Ukraine, the continued suspension of shipments to Russia, one of our key markets, affected production and sales volumes. In addition, the slowdown in the global economy against a backdrop of monetary tightening in various countries has had a serious impact on a wide range of regions, including Europe and emerging economies elsewhere, resulting in stagnant sales of low- and mid-range models. In the domestic sewing machine market, the Group has actively stimulated demand by exhibiting at and sponsoring various exhibitions, continuously disseminating information via social media, and also developing multiple "Bobinage" stores to convey the value development of sewing machines. However, sales remained weak overall due to a fallback from the stay-at-home demand seen during the COVID-19 pandemic.

**Strengths**

- Substantial product lineup from popular, widely used models to high value added products
- Continental M17, flagship model launched in April 2022
- Launching computerized quilting sewing machines Horizon Memory Craft 9480 QC Professional, Continental M8 Professional into the market
- Products made with uncompromised quality and durability but also user-friendliness
- Integrated system of planning, development, production and sales
- Distribution network covering major global markets via sales subsidiaries and distributors

**Challenges**

- Recover elsewhere lost sales to Russia
- Retain newly gained customers during the pandemic by maintaining their interest in household sewing machines
- Expedite the speed by which to launch attractive new models through capturing potential market needs, efficient product planning & development activities, a timely production & delivery to customers
- Enhance brand image further by launching value-added new models

**Business Policy**

- Maintain the value of sewing culture and sewing machines, re-evaluated by stay-at-home demand and lead the market as a leading company in the industry.
- Improve Janome global brand recognition.
- Expand sales in other regions to make up for the loss of Russian business.

**Strategies and Targets**

- Aim to expand the sales of high value added products in the essential markets of North America, Europe and Oceania.
- Increase market share in India and expand sales of light alloy aluminum sewing machines, which have established a reputation for their excellent durability.
- Dedication to offering attractive products.
- Reinforce after-sales service as well as customer support systems and strive to promote the JANOME brand through brand penetration.
- Further exploitation of latent demand through various communication channels with customers
- Identify market needs through various channels and establish market share.
- Plant seeds for future sewists by enhancing support for sewing education at schools and maintaining No. 1 share for schools in Japanese domestic market.

**Current initiatives**

- Market research, sales activities via face-to-face visits and online meetings to maintain good relationships with customers
- Sales subsidiaries and distributors are stimulating demand by spreading information via social media as well as traditional marketing activities
- Online customer support
- Further sharing of marketing tools such as video contents among sales subsidiaries

**TOPICS**

**New Products for Overseas Markets**

Following the introduction of Continental M17 in April 2022, four new computerized quilting models are introduced including Horizon Memory Craft 9480 QC Professional, Continental M8 Professional in 2023. These high value-added products will enhance our brand image and at the same time expand our position in the quilting machine market.



◀ Horizon Memory Craft 9480 QC Professional



Continental M8 Professional ▶

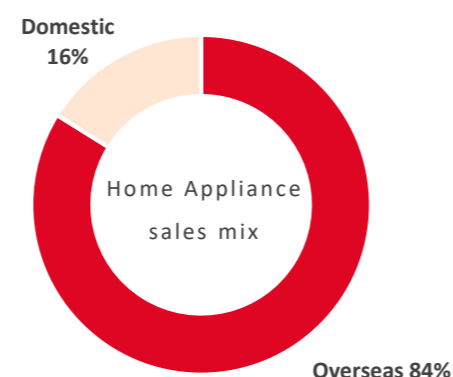
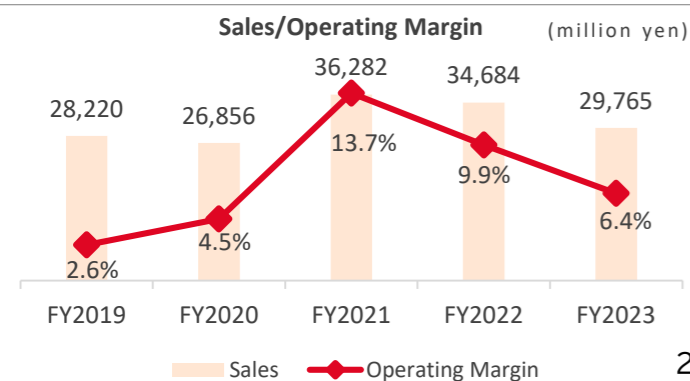



**Domestic Market (Japan): Top sewing machine manufacturer supplying attractive products through multiple sales channels**

**Business Environment: Opportunities and Risks**

- Restart direct interaction with customers via events etc.
- Diversification of sales channels for sales promotion
- Sewing machine value re-evaluated in the light of “Remake and Reuse” activities
- Decline in household purchasing power due to high prices
- Decreased contact with customers due to withdrawal of direct branches
- Accelerating further price reduction due to the prevalence of internet sales



**Strengths**

- High quality products with excellent durability and superb ease of use
- Store development to offer the experience and joy of creating your own project
- Specialist sales support group supporting customers at workshops and events
- No. 1 manufacturer for sewing machines at schools

**Challenges**

- Dig further to uncover potential sewing needs and how to expand of the sewing population
- Identify merchandizing mix that suits new lifestyles and social behavioral changes
- Providing support to aging sales staff
- Limited resources for providing sewing education by visiting schools

**Current initiatives**

- Demonstrating how to use and enjoy sewing machines via websites and social media to entice people to spend more time with their machines
- Active development of stores that attracts customers to sewing machines
- Resuming displaying sewing machines at exhibitions and events as well as workshops and sewing classes at pilot shops
- Monitor school education and maintain programs for students to familiarize them with sewing machines from a young age

**TOPICS**

**Expanding the pilot shop “Bobinage”**

Bobinage is a store designed based on a concept of being a place where people can drop by casually and realize the fun of handcraft. The store provides various workshops, rooms for creation and a rental space to meet the diverse needs of customers. The first store was opened in Kichijoji, Tokyo on March 2012 and multiple stores are planned to open with the aim of expanding the sewing population on the occasion of the 100th anniversary of the company's founding. Bobinage stores in New York, U.S. in September 2022, Kanagawa Prefecture in February 2023 and Hyogo Prefecture in May 2023 were opened. We will continue our efforts to promote the “attractiveness of sewing machines” as a leading home-use sewing machine company.



“Bobinage Kobe Motomachi (Hyogo Prefecture) opened on May 21, 2023

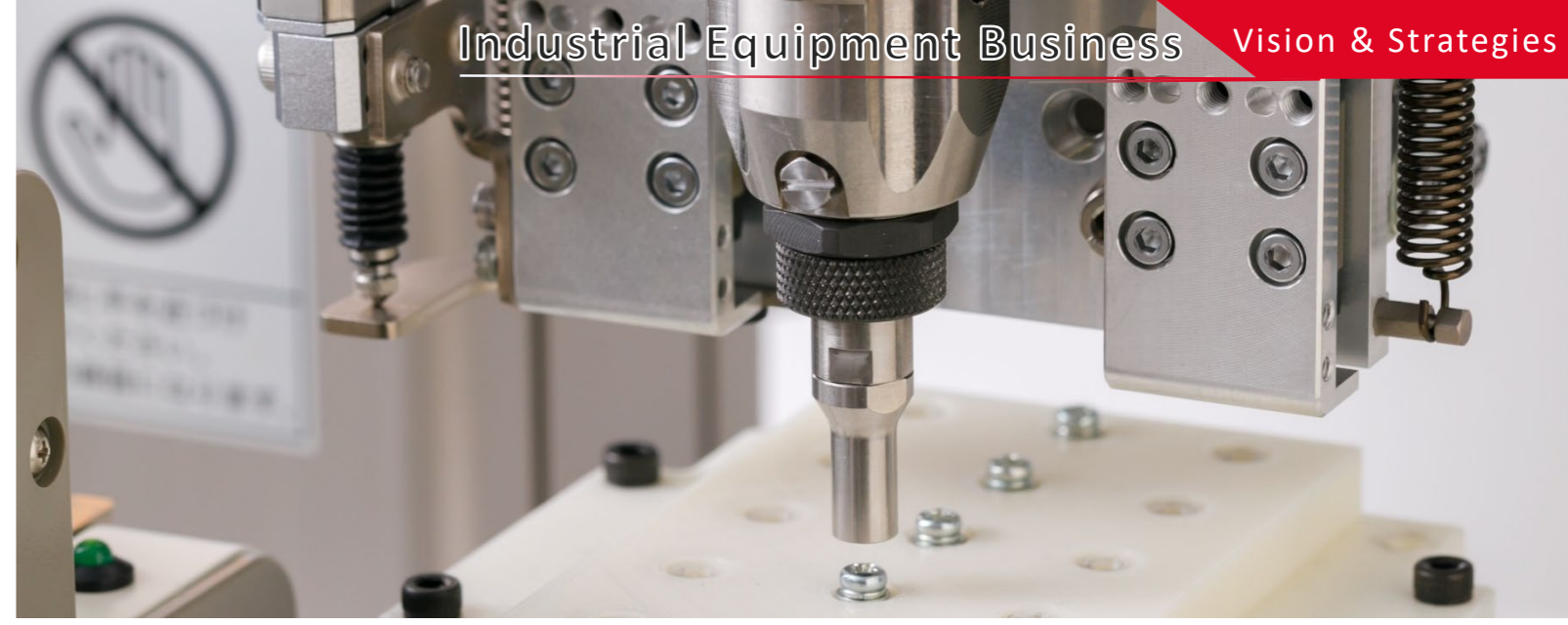

**Summary of FYE March 2023 results**

In the industrial equipment business, Janome saw a sharp increase in customer inquiries for desktop robots and Electro Presses (servo presses), especially in relation to EV production, as companies in the manufacturing sector promoted capital investment. Conversely, production continued to be affected by factors including delivery delays due to shortages of semiconductors and other electronic components, and rising manufacturing costs due to soaring raw material prices. Despite our best efforts to procure parts in advance, we were intermittently unable to make shipments on schedule. In the die-casting business, sales to the household equipment business declined, but orders from external customers remained strong due to trend toward the deployment of robot equipment at production sites.

Business Policy	
• Reinforce production capabilities and expand sales activities to establish Industrial Equipment as the second pillar of Janome Group.	• Allocate more human resources and hubs in critical markets and regions.
Strategies and Targets	
• Promote proposal-based sales while enhancing our technical and development capabilities to expand our market base to promising and undeveloped markets.	• Strengthen our manufacturing robot and servo press production capacities, while reducing costs through promoting our in-house parts production. Expand manufacturing system while decentralizing and diversifying our supply chain to mitigate risk.
• Environmental considerations and strengthening of partnerships.	– Accelerate promotional efforts to essential businesses such as the medical industry where the potential demand for Janome’s original clean room model servo press is high.
	– Promote replacement of hydraulic and pneumatic presses with servo presses for energy conservation and a safer working environment.
	– Strengthen partner company relationships in the robot and servo press businesses.
• In the die cast business, improve productivity and operational efficiency while continuing with our decarbonization efforts.	

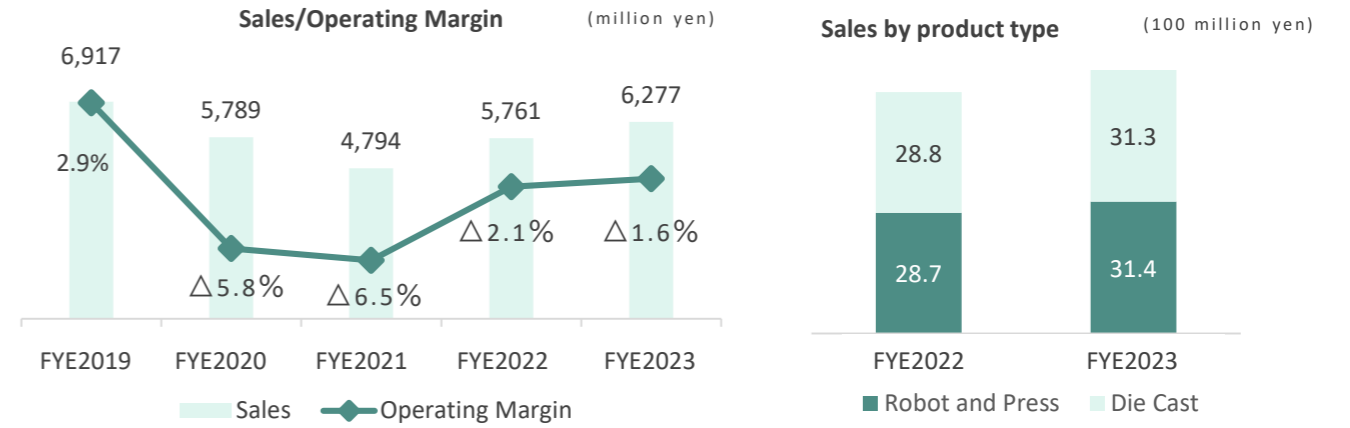



**Robot & Servo Press:** Utilizing technology cultivated in sewing machine production to contribute to industrial development

**Business Environment (Opportunity and Risk)**

- Demand for servo presses which can perform both precision assembly processes and provide quality control at the same time
- Demand for electrification of facilities to achieve carbon neutrality by 2050
- Technological innovations in information/communication networks in many countries
- Growing need for precise and fixed quantity application of adhesives and optimized screw tightening combined with position correction and inspection in the same process
- Decline in equipment demand due to the global recession, especially in China



**Strengths**

- The servo presses have acquired MF Eco Machine certification, which reduces power consumption and CO2 emissions. ( Please see p. 36 ) Additionally, environmentally friendly clean press-in equipment is used.
- Meets the requirements of a variety of standards for overseas.
- User-friendly operations by using accumulated sewing machine production technology
- Versatile robots handle a wide variety of applications including dispensing, soldering, screw tightening, PCB depaneling and camera inspection.
- Developer and seller of the industry's first lightweight servo press and a leading seller of servo presses under 20 tons.

**Challenges**

- Improve our technological edge with research and development capabilities ahead of market trends.
- Build up our sales and support force both domestically and globally to drive up sales.
- Expand product lineup and/or identify robot and press applications in growing sectors such as EV, medical and carbon neutral manufacturing
- Promote packaged sales of products and related accessories.
- Increase the scope of in-house fabrication of parts and components.

**Current Initiatives**

- Enhancing Janome's brand recognition as an industrial equipment provider while progressively breaking ground in new fields.
- Shortening the delivery lead time for die cast and related products with a high degree of precision and complexity.
- Launching new products continuously and expansion of products' lineup.
- Expanding sales of automated machines such as the Tangless Insert Automatic Insertion Machine.
- Expanding robot and servo press applications such as plasma surface treatment
- Introduction of proposal based sales which potentially leads to new product applications
- Social contribution activities such as visiting colleges of technology

\* "TANGLESS" is a registered trademark of Advanex Inc. (No. 4477416)

**TOPICS**

**Full-scale entry into the parts feeder business ~ Succession of specialized parts feeder manufacturer ARTTEC Inc. ~**

In January 2023, we began selling our own series of automatic screw feeders, and in May, we entered the parts feeder business wholeheartedly, succeeding the business of ARTTEC Co., Ltd., thereby establishing a means for providing parts feeders (automatic parts feeders), indispensable for production site automation. The parts feeder, which aligns and supplies precision parts, strongly support the automation of production sites by combining it with various cooperative robots, including our desktop robots. The addition of ARTTEC's parts feeders to our product lineup will enable both Janome and ARTTEC to respond to a wide range of customer needs by complementing each other's respective product fields.



**Die Casting Business:** Seeking the limitless possibilities offered by state of the art die cast technology

**Business Environment (Opportunity and Risk)**

- Responding to climate change including decarbonization
- Soaring raw material costs
- Changes in the business environment due to capital investment trends.

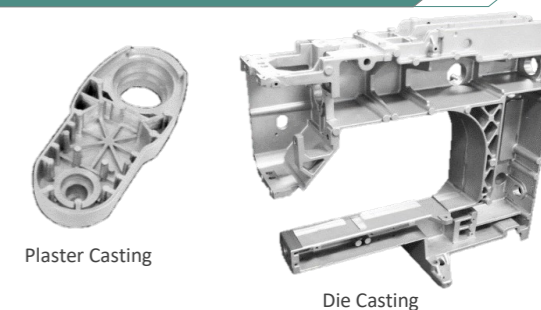

**Strengths**

- Integrated support from plaster casting prototype to mass production
- Broad production capabilities from small to large lots
- Full support from our knowledgeable technical staff
- Able to maintain same high level of quality from prototype to mass-production
- Improved prototype production speed for shorter design and development time to respond to customer requests

**Challenges**

- Decarbonization initiatives
- Improve our technological edge with research and development capabilities ahead of market trends.
- Promoting manpower and saving labor
- Promoting digital transformation

**Current Initiatives**

- Transition to automatic deburring by robot and deployment of automatic inspection equipment
- Information gathering from both machine manufacturers and the die casting industry
- Conversion of company vehicles to hybrid vehicles and electric forklift trucks
- Strengthening of cooperation with Janome Die Casting (Thailand) to promote domestic orders from customers in Thailand



**TOPICS**

**Plaster Casting ~ Unique short lead-time prototyping method ~**

Janome Die casting Coy., Ltd. Capably handles integrated production of die cast parts, from design to prototype manufacture using plaster casting to subsequent mass production of die castings. Although there are many competitors dealing with plaster casting throughout Japan, we are the only die casting manufacturer that handles the production process from start to finish, which in turn helps us offer our customers greater design flexibility, faster delivery and the highest quality standards.







**Summary of FYE March 2023 results**

In the IT business, the Group provides IT software development, information processing services, and outsourced system operation and management. Amid an increase in the number of companies engaging in digital transformation (DX), in our mainstay software development business, we strove to provide services that satisfy customers by maintaining and improving productivity through more efficient operations in a remote environment and thorough quality control.

**Business Policy**

- Drive DX strategy in the Janome Group and expand external sales of products and services based on this experience
- Establish strong position as a partner who can solve tasks together with customers

**Strategies and Targets**

- Be a partner to solve tasks together with customers based on knowledge and experiences of soon-to-start DX project within Janome group
  - Sell in-house products and expand new sales
  - From server to cloud maintenance "SaaS"
  - Support the promotion of digital transformation in Japan

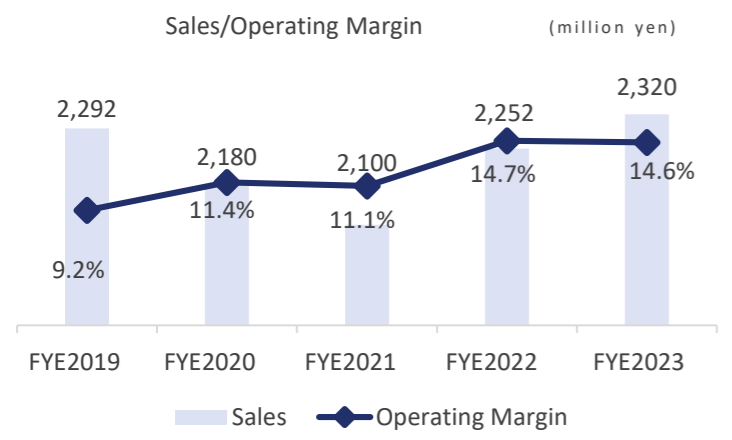

**Proposing total solution packages employing IT**

**Business Environment (Opportunity and Risk)**

- Constantly changing IT industry
- Increasingly more plagued with the talent shortage by expanding industry
- Radical DX surge
- Accelerated IT investment sparked by corporate management motivation for digital management

**PC Apps**

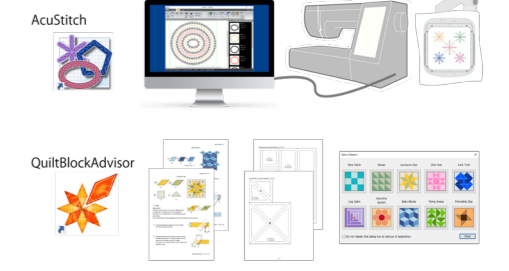

**Strength**

- IT system construction operated by the in-house server and system operations control
- Development technology of building software system with accumulated sewing machine software development
- Computer data processing system development expertise

**Challenges**

- Improve our technological edge with research and development capability one step ahead of the market trends
- Accelerate cloud system maintenance business
- Recruit and train IT engineers

**Current initiatives**

- Changing business model from existing server maintenance to cloud system maintenance
- In-house software development for sewing machine and industrial equipment products
- Sell to the third parties the expertise to be accumulated by intra group digital transformation

**Mobile Apps**



**TOPICS**

**Establishment of a department to promote Digital Transformation (DX) within the group**

The Company has established a department specifically responsible for "DX Promotion within the Janome Group," which is the main theme of the Mid-term Management Plan, and is currently under consideration. The "DX Promotion Office" has been established in the Company, and Janome Credia Co., Ltd. an IT subsidiary, has dedicated personnel within the Company, and the entire group is working together to promote DX. As for software development, the Company is proceeding with the development of (1) PC software and (2) mobile applications (iOS and Android versions) for sewing machines, and is releasing them one after the other. We are also working on the development of mobile applications (iOS and Android versions) for sewing machines.







There is a limit to what a private enterprise can do on its own not only to remain a going concern but also to generate profit for its continuous growth. Maintenance of sound relationship with and recognition by society of its value for existence, earning trust for our products and services and contribution to the development of society, repetition of this chain of actions to co-create new values with society, which we firmly believe, is the one and only path to overcome the limit and stay on the course of sustainable growth for the Janome Group.

The planet earth where we make a living, however, has never been free from difficult issues including human rights and environmental complications. These two issues have been going through worsening phases to the point where the current society system, if not the earth, will collapse, unless the deterioration is halted if not turned for the better, because the earth is above all the absolute reason not only for private enterprises like ourselves but also for all the terrestrial species including human beings.

The Janome Group will continue to Challenges for both the realization of sustainable society and the constant expansion of the corporate value of its own, while taking steps to tackle wide-ranging social issues for their solutions so that its social mission of a private enterprise is fulfilled, based on its articulate recognition and understanding that the society and the planet earth are facing critical situations on multiple matters.

### Sustainability Advancement Committee

Based on the articulate recognition of the importance of ESG management, Janome set up Sustainability Advancement Committee to accelerate promoting and approaching to sustainable management as announced in our Mid-term Business Plan, 'Reborn 2024', so that the resolutions of social challenges including SDG's are expedited.

The President chairs the committee with attendance of the Divisional General Managers where material matters concerning sustainability are discussed and challenges, targets and measures to resolve as well as the outcome of the preceding material matters resolution and evaluation thereof.

An outside director leads the meeting of the committee as we expect the discussions to go beyond the internal business decisions and/or executions to sustainability matters in breadth, depth and activation.

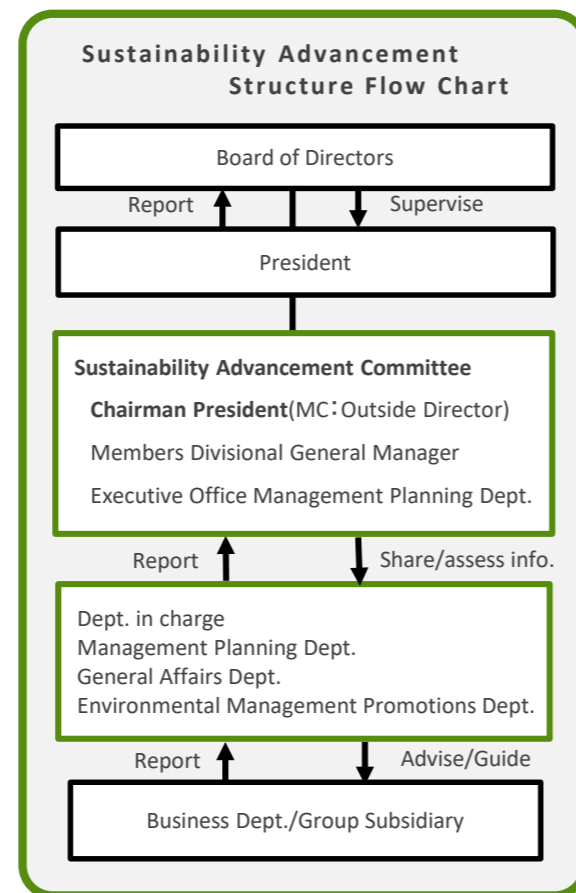

### Contributions to achieve the SDGs achievements

Janome believes contributing to realize sustainable society is one of our corporate social responsibilities and will pursue achieving each goal of SDGs by executing business operations from each perspective of ESG.

Over the past 100 years, Janome would not be here without a century of support by society, environment and people. It has been a century of incessant conflicts and war, famine and poverty in some parts of the world and human rights have sometimes been neglected. Along the process of industrial revolution and ensuing economic development, there occurred environmental destructions, pollution and waste of natural resources and social inequalities and injustices abounded in many forms and manners. Modern society faces a wide variety of challenges, which call for the global participation and cooperation of all the countries on the planet earth, if we seriously mean to solve them. Janome, as a corporate citizen, will tackle those challenges for solutions to ensure sustainable growth of our own as well as the realization of the sustainable society.



\*Sustainable development goals (SDGs) are the international commitment to realize sustainable and better world by year 2030, as documented in 'The 2030 Agenda for Sustainable Development', adopted at United Nations summit in September 2015.

### Measures to solve materiality(material issues) for sustainable growth

ESG allocation	Target theme	Actions take for	SDGs Target
Environment (Environment for the earth)	Considerations for environmental load, Environmental Preservation	<ul style="list-style-type: none"> <li>Activities to enhance the awareness of the environmental issues</li> <li>Major Environmental Objective, Activities and Achievement(P.36)</li> <li>Environmental consideration activities at respective business operations</li> <li>Actions taken for Recommendations of the TCFD</li> </ul>	
	Preparation and actions for natural disasters	<ul style="list-style-type: none"> <li>Established Business Continuity Plan</li> <li>Self defense fire drill</li> <li>Safety confirmation system training</li> </ul>	
Social (Value co-creation/ Human asset development)	Sustainable economic growth Rewarding workplace Human asset development Respect for human rights	<ul style="list-style-type: none"> <li>Procced on Mid-term Business Plan</li> <li>Actions taken for Human capital</li> </ul>	
	Workplace safety	<ul style="list-style-type: none"> <li>Health and Safety Committee</li> <li>Safe driving lecture</li> </ul>	
	Technology succession	<ul style="list-style-type: none"> <li>Improve product development capabilities</li> <li>Quality control system</li> <li>Customer support</li> </ul>	
	Social welfare activities	<ul style="list-style-type: none"> <li>Actions taken for Local communities</li> </ul>	
Governance (Corporate Governance)	Reinforcement of governance	<ul style="list-style-type: none"> <li>Reinforcement of corporate governance</li> <li>Risk management</li> <li>Compliance</li> </ul>	
	Peace and fairness	<ul style="list-style-type: none"> <li>Fair trade and procurement</li> <li>Exclusion of anti social forces, cooperation with Association of organized crime prevention</li> </ul>	

### Actions taken for Environment

Environmental issues of the earth are the global matters of concern. We strongly believe it is only natural for a private enterprise consuming sizable energy and resources for its business executions to engage in such activities as environmental load reduction and preservation of the environment.

The Janome Group would like to take this one step further to include environmental factors themselves directly in its business activities, so that environmental activities will be identified as business opportunities, achievement of which should directly expand our corporate value.

Sewing machines and industrial equipment, major products we manufacture and distribute, have inherent 'environmentally friendly and conscious' characteristics. We will improve those characteristics further in our future product development and modifications. Increased efforts will be made to promote environment related activities along the line of Janome's 'Environment Policy' and its bylaw 'Green Procurement Guidelines' on top of the factors regarding environmental load reduction already built-in from the supply chain and production phase to every other phase of our business activities.

### Group Environment Policies

#### 【Philosophy】

The Janome Group is resolved to conduct its corporate activities while paying appropriate attention to conserve the natural environment as well as to contribute to sustainable development of society, based on the recognition that one of the most significant universal challenges to mankind is to 'conserve the global environment where man lives in harmony with nature'.

#### 【Policies】

1. Janome takes on a challenge to reduce CO2 (carbon dioxide) emissions in every phase from the production to delivery of its products and services.
2. Janome promotes the 3R movement, namely 'Reduce', 'Reuse' and 'Recycle', in every phase of its business process to conserve resources as well as to reduce energy consumption.
3. Janome also aims to contribute to society from an environmental perspective, by creating products and services that help reduce environmental load.
4. Janome maintains strict control of hazardous substances that are detrimental to people and the environment, thereby aiming to reduce environmental risks.
5. Janome proactively discloses its overall environmental consideration activities.

JANOME Corporation  
President  
Makoto Saito

### Activities to enhance the awareness of the environmental issues

Employees with their family of Janome Diecasting (Thailand) Co., Ltd., having its business in the country periodically engages in planting trees of padauk, rosewood and other native South East Asian trees as well as releasing juvenile white snapper\* to the ocean in Rayong, Thailand. Our group company challenges various activities for the purpose of preventing global warming and protecting oceanic eco system which also helps to foster the awareness of environmental conservation.

※ White snapper is a type of fish classified in the family of sea bass and snappers, and is a popular fish eaten in Thailand and other popular households.



Tree planting activities



Releasing juvenile fish

### Major Environmental Objective, Activities and Achievement

Janome group set environmental targets and conduct activities in accordance with the Group Environmental Policy and the environmental policies of each group company. Objectives, activities and achievement are shown below. We are developing activities to reduce environmental impact by understanding the environmental impact generated by our business activities.

Theme	Key Environmental Objective	Site	Milestone Achievement																		
3Rs (reduce, reuse, *recycle) promotion	*Recycle by strict waste separation	All sites	<ul style="list-style-type: none"> <li>Recycle box installed at every business unit in the Head Office building</li> <li>Recycled polypropylene band &amp; cardboard box</li> </ul>																		
Conserve Energy and resources	*Energy conservation by individual business and operation unit	All sites	<ul style="list-style-type: none"> <li>Introduce and replace with LED (light emitting diode)</li> <li>Solar power generation system</li> <li>Replace with environment-conscious equipment, etc.</li> </ul>																		
*Reduce CO2 *output volume	*Lower than preceding fiscal year results	All sites	<ul style="list-style-type: none"> <li>See graph below ※Fiscal Year 2021</li> <li>Actions taken for Recommendations of the TCFD (detailed on page 38)</li> </ul>																		
*Develop *environment-*friendly product	*Mainly of sewing machine & *industrial equipment	Head office	<ul style="list-style-type: none"> <li>Activities at Research &amp; Development (detailed on page 36)</li> </ul>																		
*Toxic substance *control	*Reduce chemical substance usage/ due care and management	All sites	<ul style="list-style-type: none"> <li>Conduct appropriate management and surveys, fully aware of the impact on the human body and the environment</li> <li>Reduced hydraulic leak (Diecast Thailand)</li> </ul>																		
*Disclosure of *information	*Publication of JANOME REPORT	Head office	<ul style="list-style-type: none"> <li>Published 'JANOME REPORT 2022'</li> </ul>																		
*Maintain and *improve *environmental *management system	*Renew and retain certificate of ISO14001 and Eco-action 21	All sites	<ul style="list-style-type: none"> <li>Renewal and retention of ISO14001 and Eco-action 21</li> </ul> <table border="1"> <thead> <tr> <th>Company Name</th> <th>ISO14001</th> <th>ISO9001</th> </tr> </thead> <tbody> <tr> <td>Head office</td> <td>○</td> <td>○</td> </tr> <tr> <td>Diecast</td> <td>— (Eco-action 21)</td> <td>○</td> </tr> <tr> <td>Taiwan</td> <td>○</td> <td>○</td> </tr> <tr> <td>Thailand</td> <td>○</td> <td>○</td> </tr> <tr> <td>Diecast Thailand</td> <td>○</td> <td>○</td> </tr> </tbody> </table>	Company Name	ISO14001	ISO9001	Head office	○	○	Diecast	— (Eco-action 21)	○	Taiwan	○	○	Thailand	○	○	Diecast Thailand	○	○
			Company Name	ISO14001	ISO9001																
			Head office	○	○																
			Diecast	— (Eco-action 21)	○																
			Taiwan	○	○																
			Thailand	○	○																
Diecast Thailand	○	○																			
Environmental Education	Head office	<ul style="list-style-type: none"> <li>Educate candidates to qualify for internal environmental auditor</li> <li>In addition, Intranet Portal Site periodically posts 'Mini Correspondence on chemical substance and hazardous material' correspondence on the issues of the time such as new regulations on chemical substance control and information on hazardous materials.</li> </ul>																			
		<ul style="list-style-type: none"> <li>Complied with all the laws and regulations on air and water pollution and noise control of each country where we have business operations in</li> </ul>																			
*Comply with the environmental laws and regulations of the countries we have business *operations at	All sites																				

Head office ⇒ Janome Corporation / Diecast ⇒ Janome Diecasting Co., Ltd./

Taiwan ⇒ Janome Taiwan Co., Ltd. / Thailand ⇒ Janome Thailand Co., Ltd. / Diecast Thailand ⇒ Janome Diecasting (Thailand) Co., Ltd.

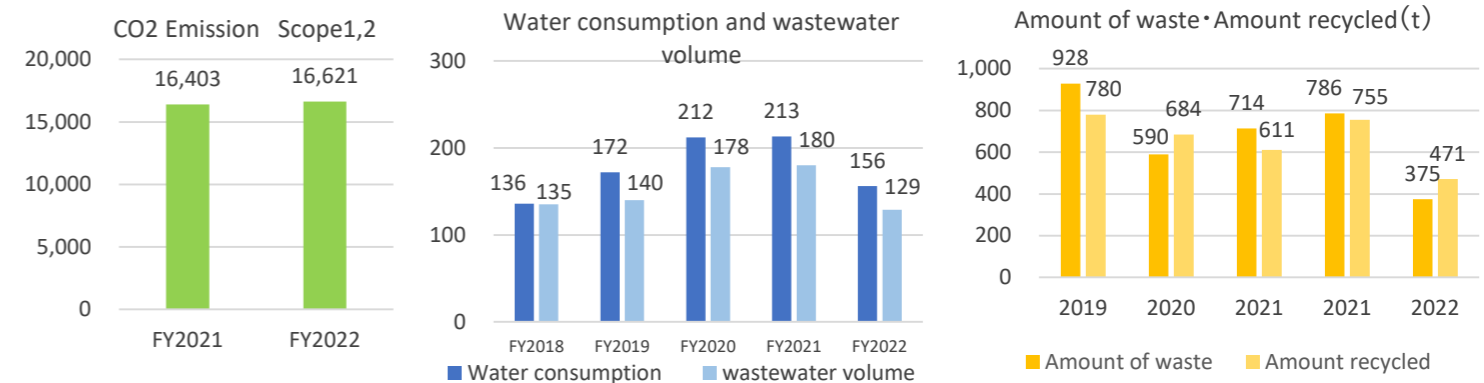

※CO2 emissions of the Company and its consolidated subsidiaries in fiscal 2022 are currently being compiled and its consolidated subsidiaries in fiscal 2022 are currently being compiled  
Scope of aggregation: Janome Corporation, Janome Diecasting Co., Ltd, Janome Taiwan Co., Ltd, Janome Thailand Co., Ltd, Janome Diecasting Thailand Co., Ltd

※The amount of waste and recycling in FY2022 The classification of the aggregate has been changed in the following table.



## Environmental consideration activities at respective business operations



Let us present our environmental consideration activities at respective business operations.

### Actions taken for Research & Development Operations

In our effort to reduce the negative burden that our products themselves may have on the environment, Janome takes on such challenges as below in the research and development stage of our home appliance and industrial equipment products.

- Natural resources conservation:
- Weight reduction, volume downsizing, parts sharing, maintaining ease of disassembling
- Electricity conservation: Reduction of electricity consumption in standby and in power mode
- Extension of products life span:
- Introduction of highly durable parts and upgrading current version by external connection
- Reduction of hazardous substance usage:
- Compliance with the regulations on chemical substances contained in products

ABS resin (Note 1 below) used for external parts, for certain recently developed sewing machines is reduced as compared to the existing models. Promotion is under way for energy conserving and long-life LED lights.

On top of the universal challenges above, original evaluation standards are employed for industrial equipment development to give further consideration to the environment. A summary of the standards is below.



MC9450QCP equipped with LED lights

Note 1. ABS resin is a collective term of acrylonitrile butadiene styrene copolymerized synthetic resin

Recyclability	percentage usage of recyclable ferrous metal parts and renewable resin parts to the total parts
Compliance with safety regulations	structure and design complying with laws and regulations that the intended destinations require such as RoHS Directive, REACH Regulation, UL Standards, CE Marking, KCs Mark (Korean Certification Mark), OSHA, etc.
Others	Promote further unitization, improve assimilability, increase exchangeability of maintenance parts



New servo press models were tested using the same evaluation standards for existing models and fared equally or better than the existing models in all criteria. New models are also equipped with a two-hand control devices, 'Switch Boxes'—an additional safety feature for the operator in compliance with EN574. Even when making considerations for safety and the environment, we do not compromise on functions and features—the fundamental value of our industrial equipment.

※ EN574 dictates safety requirements for designing and selecting two-hand control devices.

## Environmentally Friendly Products

We are committed to contributing to society from an environmental perspective by creating products that help reduce environmental impact.

### Janome Servo Press compatible with clean room

Janome offers a high precision servo press compatible with clean room standard Class 10, equivalent to ISO146441-1 Class 4, as a prospective product for the medical market.

Main features are as follows:

- Special airtight construction prevents dust generation
- Conductive coating on press exterior stops static electricity
- Press is usable both inside and outside of a clean room environment

We are also making an effort to help customers replace hydraulic and pneumatic presses with our more environmentally friendly electrically powered presses.



Clean Room Compatible JP Series 5 Two-Handed Switch Model

### TOPICS JP Series Certified Ecologically Friendly

Our JP Series 5 servo presses are "MF Eco machine" certified by the Japan Forming Machinery Association (JFMA)\* as environmentally friendly products. One requirement for certification is a reduction in total power consumption of 20% or more compared with conventional machines. The JP Series 5 achieves energy savings by reducing power consumption by 23% or more compared with conventional pressing machines. In addition, the JP Series 5 is a safe and environmentally friendly product which meets various domestic and international standards for safety, hazardous substances, and other environmental requirements.



※The Japan Forming Machinery Association established its own specialized "MF Eco machine" certification criteria, which a certification council consisting of JFMA members and outside experts use to evaluate, certify, register and publicize "MF Eco machine" products.

### Actions taken for Procurement Operations

Janome Group documented 'Green Procurement Guidelines' in 2011, and has been monitoring, in coordination with each production business unit, to remain compliant with various regulations on chemical substances contained in our products. We are also monitoring, in cooperation with our suppliers, to ensure that prohibited substances are not used at all or are used to the extent allowed, and to demand correction in case there exist any non-compliance on the part of any supplier with relevant regulations.

### Actions taken for Production and Distribution Operations

Each production hub is taking steps to streamline its operations and to reduce overall manufacturing cost as well as to reinforce and improve its electricity saving and environmentally friendly operation system, while constantly monitoring the necessity for renewal and repair of its production system. Additionally, appropriate storage and disposal of waste water and oil discharged during production is strictly monitored to maintain operational compliance with the environmental considerations. Use of returnable steel pallets for delivery from Janome Taiwan Co., Ltd to Tokyo Factory has gradually been expanding for some time, while these pallets, on their way back to Janome Taiwan Co., Ltd, are stored in idle space of a container of parts shipment to Taiwan, saving an extra transportation cost.

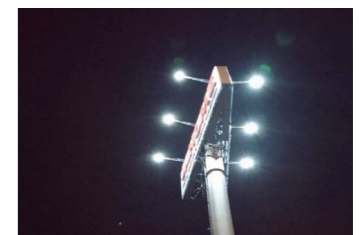

Lighting operated by solar cell Janome Thailand, Co., Ltd.



Replaced air conditioners with air-cooled chillers Janome Thailand, Co., Ltd.

**Actions taken for Recommendations of the TCFD**



The Janome Group, as a corporate citizen of the society, is proactively taking actions to cope with environmental issues including reduction of GHG (greenhouse gas) emissions. The topic was elevated to one of the material challenges to tackle immediately when the Sustainability Advancement Committee was established in April 2022 involving the management ranks. The committee has been the driving force to assess the risks and opportunities of the climate change to the Janome Group to elevate the level of our disclosure in line with the recommendations of the TCFD, Task Force on Climate-related Financial Disclosures.

**Corporate Governance**

Janome aims to both help realize sustainable society and medium to long term expansion of the corporate value by taking into account sustainability factors in its management decisions.

Sustainability Advancement Committee, chaired by the President with the participation of the key members across the organization, controls the Group’s overall environmental activities including those regarding climate change.

The committee, held periodically, deliberates material matters on climate change, determines the challenges, targets and measures as well as assesses the validity. An outside director leads the committee to include objective views on material matters concerning sustainability to avoid leaning on the decision making based on the internal logics.

Management Planning Dept., General Affairs Dept. and Environmental Management Promotions Dept. are in charge of following up on the actions of each department and subsidiary and they make a report for progress and situation at the Sustainability Advancement Committee. Summary of such deliberations are reported to Board of Directors more than twice a year, who in turn supervises the environmental activities of the entire Janome Group as well as determines important policies regarding climate change and reflect them in the management policies and business strategies.

**[Governance and Risk Management Structure on Climate Change]**

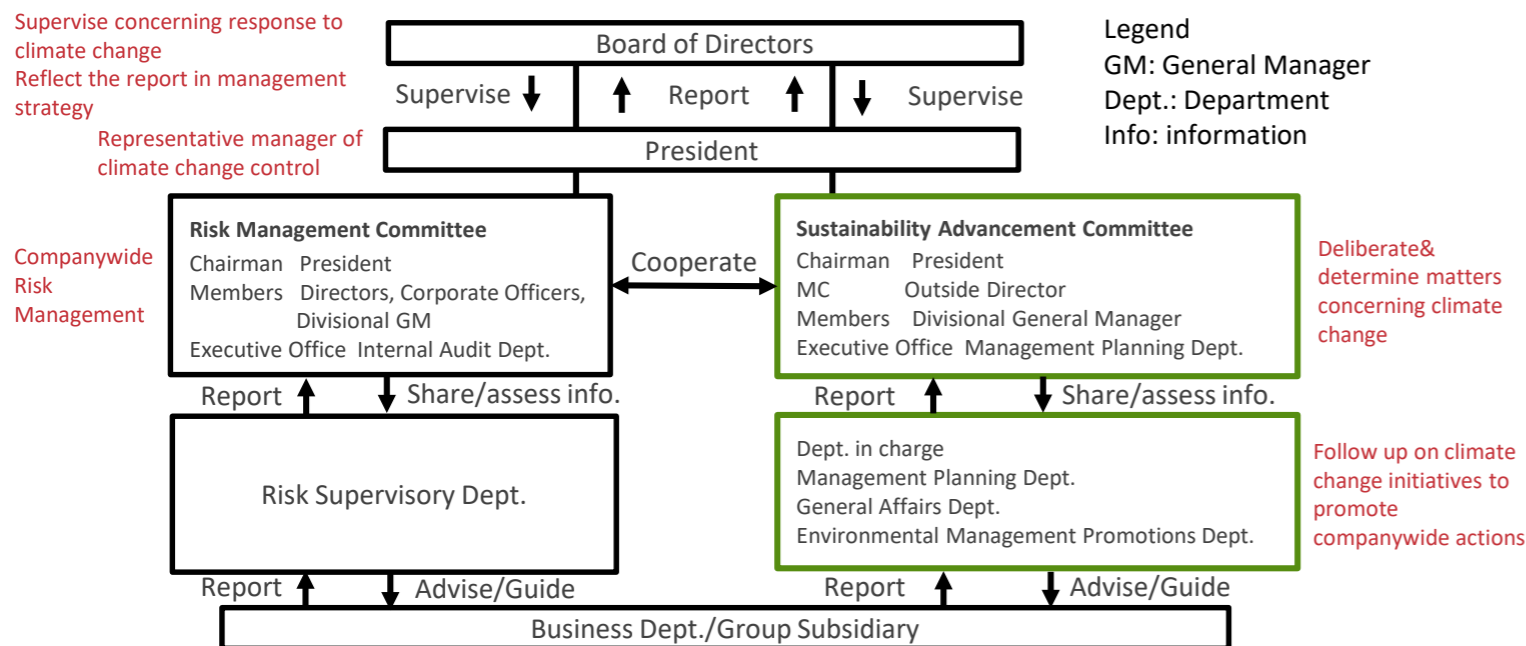

**Risk Management**

Janome established the Risk Management Committee to control the companywide risk management, who grasps the update of the risks and the opportunities each business unit and group subsidiary is facing and to deliberate the appropriate actions to take and report to the Board of Directors more than twice a year.

The risks and the opportunities concerning climate change are shared with the Sustainability Advancement Committee, where the priority and specific actions are determined after deliberation with the outcome of the committee to be reported to the Board of Directors.

The Board of Directors receives reports from both the Risk Management Committee and the Sustainability Advancement Committee and supervises them.

**[Climate change risks & opportunities control process]**

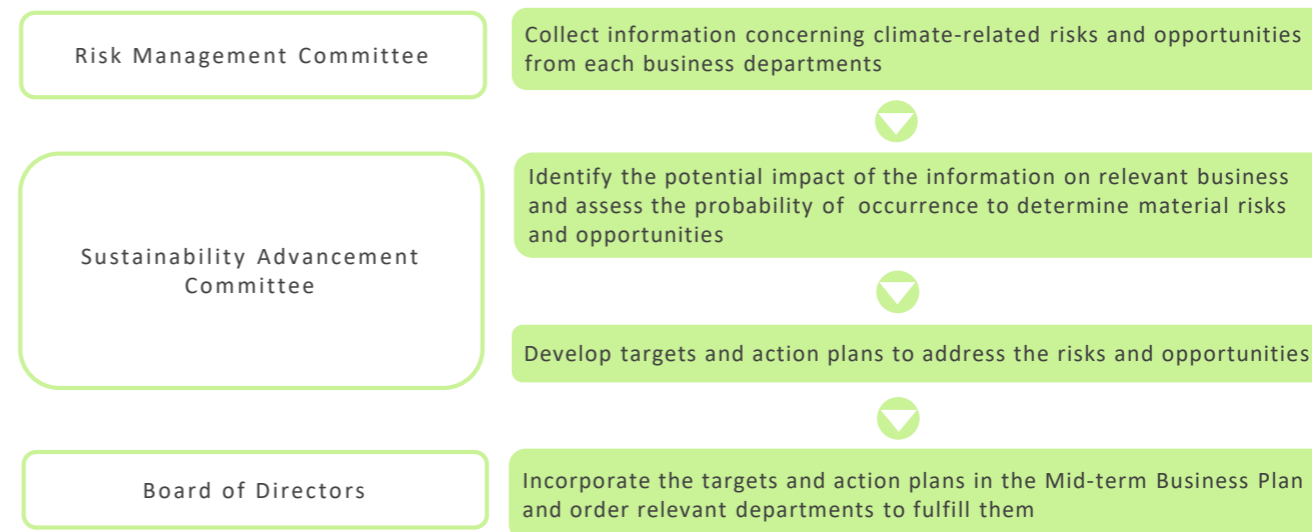

**Strategies**

A scenario analysis was conducted based on 2°C and 4°C rise scenarios based on TCFD recommendations, and identified the risks and opportunities on the value chain including our business and assessed the potential financial impacts thereof. As a result, scenario analysis revealed that 4°C rise does more harm to de-carbonization, but rather gives rise to increased occurrences of natural disasters with catastrophic intensity, exerting us to address more physical damages to the production facilities and the supply chain. Whereas, 2°C rise scenario impacts production and procurement in terms of the increased cost to comply with new laws, regulations such as carbon tax and increased use of plastic regulations. As de-carbonization progresses, we will recognize as opportunities increasing replacement demand for environment-conscious products, lower carbon material, improving energy efficiency features and further commoditization of parts as consumer behavior changes highlighting demands for environmentally-friendly products.



[Climate-related Risks and Opportunities for the Janome Group]

[Time Line]  
 Short term: Present ~ around year 2025)  
 Medium term: around year 2030  
 Long term: around year 2050

Type	Climate-related Risks & opportunities		Potential Financial Impacts	Categories	Timeline	
Risks	Transitional	Policy & Legal	Carbon Tax / Emission Trading Scheme	Increased operating and energy costs triggered by the introduction of carbon tax and emission trading scheme	Expenditure	Medium to Long term
				Increased selection and implementation costs associated with the research and introduction of alternative resources triggered by the plastic regulations and additional costs of voluntary recall of the existing products	Expenditure	Medium to Long term
		Market	Energy cost fluctuation	Increased cost to purchase green power to comply with the increased renewable energy ratio	Expenditure	Medium to Long term
	Increased cost of components & parts		Global shortage of energy saving components driven by the same competition in response to the growing needs for energy saving measures pushed up the cost of goods purchased	Expenditure	Medium to Long term	
	Changing customer behavior Uncertainty in market signals		Loss of sales opportunity due to the delay in response to the rising expectation of customers for environmentally conscious products	Revenue	Medium to Long term	
	Physical	Acute	Increased occurrence of natural disasters	Increased occurrence of typhoon, thunder, torrential down pour give rise to the risk of flood and blackout which may prevent employees from coming to work, or lead to the factory shutdown, which involves the risk of sales opportunity loss by prolonged shutdown period, capital cost of repairing the damaged facility, increased insurance premium and interruption of parts procurement due to the supply chain stoppage.	Expenditure / Asset	Medium to Long term
Chronic		Changes in environment due to global warming	Rising temperature reduces cooling efficiency of the building housing production facility leading to deteriorate the working environment and may result in increasing operational errors and reducing productivity as well as accelerating employee turnover.	Expenditure / Asset	Long term	
Opportunities	Energy Source	Enter into Carbon Market	In comparison to hydraulic and pneumatic press, servo press needs only 10 to 20% of electricity in reproducing low noise and clean environment, which is less harsh for the operator and the work itself. On top of CO2 emission reduction, it is expected to reduce parts disposal achieved by precision pressure control reducing the defection rate, contributing to conserving the environment.	Revenue	Medium to Long term	
	Products & Services	Development and/or expansion of low emission goods and services	Accelerated usage of low carbon materials, further introduction of electricity saving products and common application of necessary parts will be sought so that consumers may possibly identify more values to the products.	Revenue	Medium to Long term	
	Resilience	Participation in renewable energy programs and adoption of energy efficiency measures. Resource substitutes/	Create new demand by launching products employing brand new technology.	Revenue	Long term	

Metrics and Targets

The Janome Group, with its global operations, is exposed to various impacts climate change may exact. Not to mention its inherent needs as a going concern to minimize those impacts for the stable continuation of its businesses, Janome believes, as a corporate citizen, it is endowed with a social mission to proactively engage with environmental issues for legitimate solutions.

With this understanding as a first step of engagement with climate change, we calculated in line with GHG protocol CO<sub>2</sub> emissions of our business activities for the fiscal year 2021<sup>※</sup> as follows: Scope 1, 2 aggregates Janome Corporation and its consolidated subsidiaries, showing 16,621ton, Scope 3 representing Janome Corporation alone, showing 113,567ton.

Next step is to discuss and elaborate on those metrics to determine numerical CO<sub>2</sub> emission reduction target as well as practical measures to reach those targets, with Sustainability Advancement Committee taking initiative to guide the discussion and determination on the right track.

The Janome Group is always engage with more environmental conscious business activities to seek realizing sustainable society and increasing corporate value further.

※CO<sub>2</sub> emissions of the year 2022 of Janome and consolidated subsidiaries are being calculated at the moment.



### Actions Taken for Society

The Janome group believes that it can fulfill its role as a public company within society by building good relationships with many people in various aspects of society and earning their trust and confidence. Recognizing that “people” are the most important factor for contributing to society through the provision of valuable products and services, we are continuously working to educate all employees, including managers. Human resource education is one of the most important management issues, and we will maintain our stance that the entire company is involved in human resource development, including top management and others fully involved in education and training, with the aim of realizing our corporate philosophy and improving business performance.

### Actions Taken for Human Resource

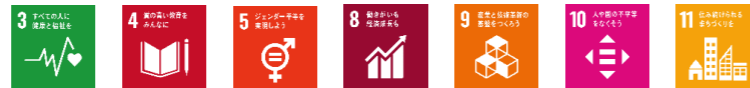

#### Human Resources Development Policy

The Group considers people to be the most important factor of a company, because a company is run by people and is supported and grows through the vitality of its people. In accounting, people tend to be recognized as labor and labor costs, but we believe that people should be positioned as capital because they are the backbone of a company. Therefore, even in favorable or unfavorable business conditions, recruitment and training must naturally be carried out continuously and reliably. For this reason, we believe people are assets.

#### Policy

1. Janome provides opportunities to reward and support each employee's "desire to grow" and "need for change." Each employee will proactively and willingly pursue self-growth and self-improvement.
2. As the level of growth increases, Janome will gradually move from "teaching" to "learning" and then to "thinking" education.
3. Janome strives to provide employees with opportunities to gain beneficial experiences, as learning through work experience brings about significant growth.
4. Some educational issues require urgency and immediate effect, but in general, human resource education is not, and should not be, a quick-fix process. The key is for people to challenge each other robustly, continue to grow together (co-education), and enhance each other's skills.

#### Main Educational Areas

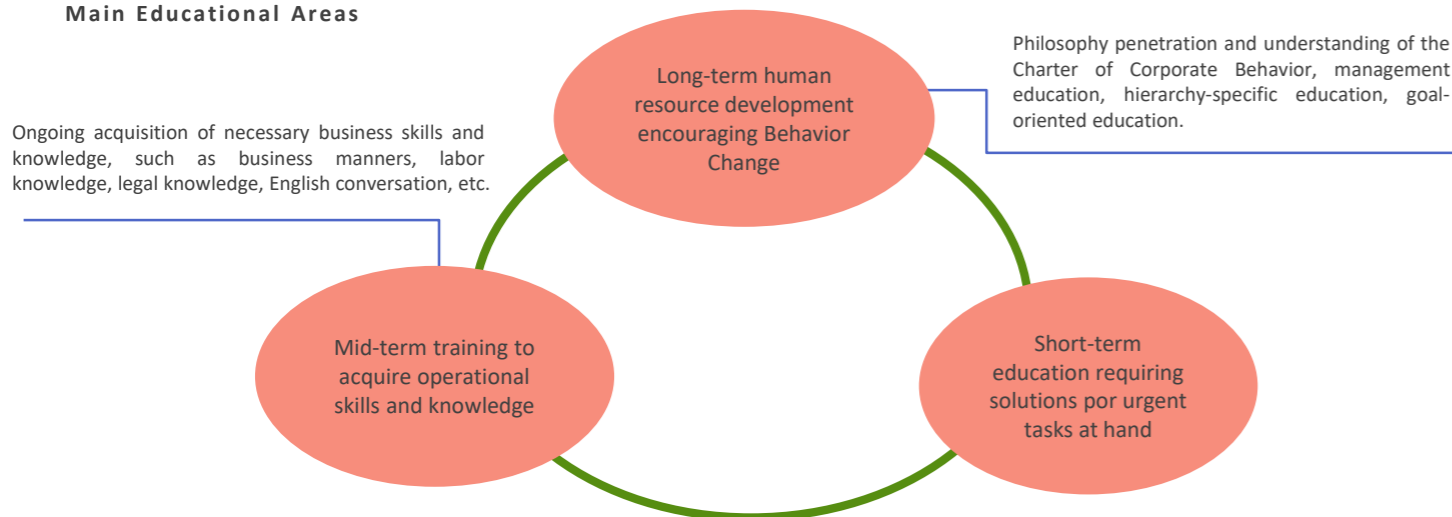

As one example, as part of rank-specific education, we conduct "third year training" for employees in their third year with the company, with the objective of clarifying their own strengths and abilities and determining their future direction by reviewing their past work experience and recognizing the importance of autonomous career development. Other initiatives to promote self-development include online English conversation training, correspondence courses, and e-learning for those who wish to participate.

#### In-House Environmental Improvement Policy

The Janome Group is committed to creating a better working environment. We take health checks and stress management on a regular basis to keep our employees healthy and have safety as a top priority. Through the activities of the Health and Safety Committee, we work to prevent workplace accidents and improve the working environment by promoting safety measures and an accident reporting system. Furthermore, with the aim of improving the internal environment and making it easier for employees to work, we are promoting the following initiatives to improve the workplace environment and make it suitable for business execution as well as a work environment prepared for safety and health.

#### Promoting Work Style Reforms

Janome has employees with diverse backgrounds, both men and women, working in permanent and non-permanent positions. We are endeavoring to make the company an even better place to work in order to for achieve better business performance, improve productivity, and allow our staff to enjoy fulfilling personal lives outside the company. To achieve work-life balance, we have established a system that facilitates employees to take leave and work in accordance with life events such as childbirth, childcare, and nursing care. Although long working hours are not the norm at our company, we intend to further reduce overtime hours and promote the use of annual paid leave by reviewing the way we approach our work and business processes and by introducing digital tools. This will improve labor productivity and enhance work-life balance.

In addition, we have long been proactive in creating a support system for balancing work and nursing care, and in 2020 we acquired the Tomonin Mark, a symbol for promoting the development of a "workplace environment that allows the balancing of work and nursing care".



Tomonin symbol mark

**Average monthly overtime hours (FY2022)**

**5.8** hours

#### Major efforts to prevent long working hours

- Every Wednesday is designated as "No Overtime Day" and announcements are made twice a day (at the beginning and end of the workday) to encourage employees to leave the office on time and go home.
- In addition to prohibiting workers from working after 10:00 p.m., the company also compiles a monthly tally of overtime work and issues warnings to departments that work too many overtime hours. Departments that work too many overtime hours are warned.

**Average number of days of paid leave (FY2022)**

**13.8** days

#### Major efforts that allow employees to take leave for rest and relaxation

- Encouragement of extended leave (3 or more days at a time) and a refreshment leave system have been introduced.
- Half-day and hourly paid leave are available.



### Promotion of Women's Activities

Janome group respects gender diversity, and in particular, with regard to the promotion of women's activities, we believe that the full utilization of the abilities of female employees contributes to the development of the company, and we take for granted the enhancement of the childcare leave system and equal opportunity between men and women when assessing salary increases and promotions.

Janome designed in 2020 the 'Voluntary Action Plan regarding promoting female employees to the managerial ranks including directorship', setting 'the target to increase by 2025 the ratio of female managers among all managers to 20%'.

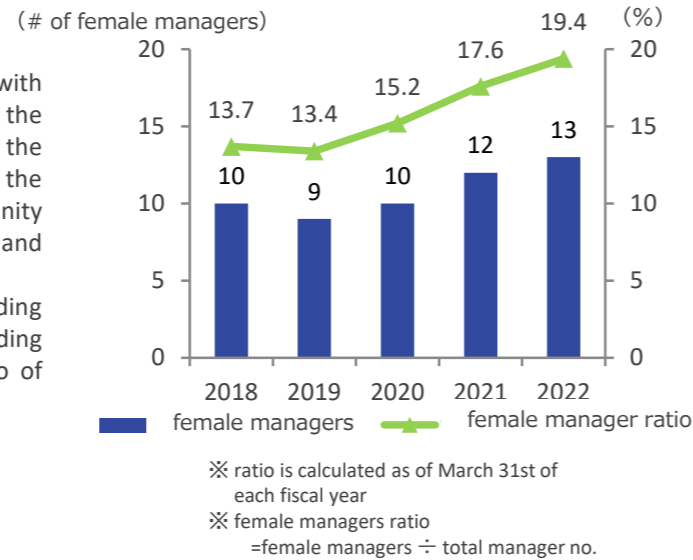

### Enhancement of Childcare Support Programs

- Janome obtained in 2008 the 'Kurumin\* Mark', a certificate given by the Ministry of Health
- Parental leave can be taken until the child turns 3 years old, and can be taken in two installments.
- Janome Introduced a paternity leave system', allowing up to 14 days of paid leave during this leave period.
- After returning to work, employees can work shorter hours until the end of the school year when the child enters the second grade of elementary school, and can take leave to care for a child before elementary school. Up to five days of leave can be taken in one-hour increments.

No. of births and nursing care leave takers		FY2019	FY2020	FY2021	FY2022
No. of births / Nursing care leave takers	Female	4/4	2/2	5/5	6/6
	Male	1/9	2/6	2/5	※6/5

※The number of employees who took childcare leave increased by one because they did not take childcare leave in the relevant fiscal year in which the child was born, but took leave in the following fiscal year or later.

### Respect for Human Rights

Janome has established an internal committee, 'Human Rights Education Promotions Committee', driven by the awareness that it is one of the corporate social responsibilities to promote human rights education activities. The committee is a driving force to stage human rights education seminars to enhance each and every employee's awareness of human rights, thereby creating a comfortable working environment for all to respect each other's human rights without prejudice to sex, age, sexual orientation or disability. As part of the promotions, instructors/experts are invited to conduct seminars on human rights education, and DVD viewing sessions are orchestrated for employees to learn the related issues and information. One week in December is designated as The Human Rights Education Week, when we recruit from employees and their families a motto to promote the activity, and the internal competition winners' mottos are sent to external organizations for further competitions. These are some of the activities in which we engage, in our effort to enhance and spread awareness of human rights across the entire Janome Group.

Janome, as a member of the 'Tokyo Board of Corporate Correspondence for Human Rights' as well as other boards, has been participating as a corporate citizen in activities aimed at enhancing human rights awareness of society, with also a wish to establish respecting human rights as Janome's corporate culture.



### Actions taken for Local Communities

Janome is always willing to proactively deal with various stakeholders, as we value developing and maintaining close connections with society.

#### Company tour for the 1st graders of Tokyo Metropolitan Hachioji-Nishi Special-Needs Education School

Starting in July 2022, Janome has invited 1st grade students of the school to a company tour of our Head Office.

The Company tour is one of the annual school events designed to encourage students to think about their own career paths. Students are invited to our Head Office for a lecture on "What it means to work" by the Human Resources Department, a tour of the company, and hands-on work experience.

The school also incorporates "work training" as part of its vocational training, and we continue to provide a training site. We will continue to value our ties with the local community and continue to work with them in various ways.



#### TOPICS Teaching Future Robotics Engineers through CHERSI

Janome proudly participates in CHERSI\*, an initiative to develop new human resources through collaboration between robot manufacturers, system integrators, and other industrial sectors, and educational institutions such as technical colleges and technical high schools.

In February 2023, we held a robot school for students of the Tokyo National College of Technology (Hachioji City, Tokyo) with a lecture on the inner mechanism of our desktop robots. Our robot school also gave the students valuable hands-on training with our demonstration machines as they learned how to program and operate our robots for work in applications such as dispensing, screw tightening, and printed circuit board cutting.

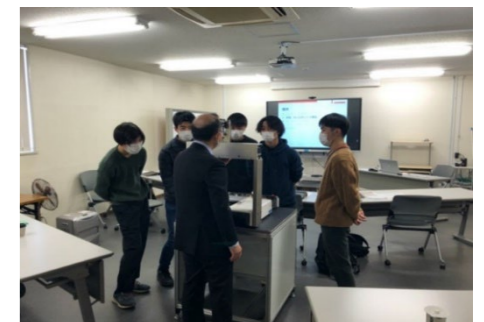

Robot School Classroom

\*CHERSI is the acronym for The Consortium of Human Education for Future Robot System Integration.

### Other actions for Society

#### Making donations to nearby schools on Children's Day

Janome Thailand Co., Ltd. donated 47 towels and umbrellas to a nearby school on Children's Day (the second Saturday in January).



#### Supporting elementary school playgrounds

Janome Diecasting Co., Ltd. had its employees maintain a playground at a nearby elementary school (Bang Khlong Voong School) as part of its contribution to the local community.



(As of October 1<sup>st</sup> 2023)

## Directors



President

**Makoto Saito**

In charge of Internal Audit

April 1978 Joined the Company  
 April 2011 Corporate Officer  
 April 2015 Managing Officer  
 June 2017 Director  
 April 2018 Senior Managing Officer  
 June 2019 President,  
 In charge of Internal Audit Department (current position)

Director  
Senior Managing Officer**Toshiya Takayasu**Industrial Equipment Sales  
Division Head  
President of Janome Industrial  
Equipment (Shanghai) Co., Ltd.

April 1987 Joined the Company  
 April 2013 Corporate Officer  
 April 2016 Managing Officer  
 June 2016 Director (current position)  
 April 2018 Senior Managing Officer (current position)  
 June 2021 Industrial Equipment Sales Division Head (current position)  
 June 2023 Chairman of Janome Industrial Equipment (Shanghai) Co., Ltd.  
 (current position)

Director  
Senior Managing Officer**Hitoshi Doi**Administration Division Head  
Chairman of Janome Credia Co., Ltd.

April 1985 Joined Saitama Bank, Limited (currently Resona Bank, Limited)  
 April 2020 Managing Officer, the Company  
 June 2020 Director (current position)  
 April 2021 Senior Managing Officer (current position)  
 May 2022 Chairman of Janome Credia Co., Ltd.(current position)  
 Oct. 2023 Administration Division Head (current position)

Director  
Managing Officer**Kazushi Kawaguchi**Production Management Division Head  
In charge of Quality Assurance Department  
Chairman of Janome Taiwan, Co., Ltd.

April 1982 Joined the Company  
 April 2016 Corporate Officer  
 April 2019 Managing Officer  
 June 2019 Production Management Division Head, the Company  
 Chairman of Janome Taiwan, Co., Ltd. (current position)  
 June 2020 Director, In charge of Quality Assurance Department the Company  
 (current position)  
 April 2021 Senior Managing Officer  
 April 2023 Managing Officer (current position)

Director  
Managing Officer**Takeyuki Oshima**In charge of Home Appliance International  
Business Division  
In charge of Home Appliance Domestic  
Business Division

April 1987 Joined the Company  
 June 2017 Corporate Officer  
 April 2021 Managing Officer (current position)  
 June 2022 Director (current position)  
 Oct. 2023 In charge of Home Appliance International Business Division,  
 In charge of Home Appliance Business Division(current position)

Outside Director  
(Independent)**Fumiaki Nakajima**

April 1983 Joined Showa Electric Wire and Cable Co., Ltd.  
 (currently SWCC Showa Holdings Co., Ltd.)  
 June 2016 Representative Director and President  
 June 2019 Director, the Company (current position)  
 April 2020 Outside Director, Tokyo Water Co., Ltd.  
 Audit and Supervisory Committee Member(current position)  
 Jan. 2021 Executive Officer, Divisional Associate General Manager of  
 International Division, Senshu Electric Co., Ltd. (current position)

Outside Director  
(Independent)**Shoko Sugino**

April 1973 Registered as attorney, Joined Fujibayashi Law Firm  
 April 1994 Partner (current position)  
 June 2018 Corporate Auditor, Takeei Corporation(current position)  
 June 2019 Outside Director, Japan Securities Finance Co., Ltd.(current  
 position)  
 June 2022 Director, the Company (current position)

Outside Director  
(Independent)**Yasuyo Tanaka**

Mar. 1979 Joined Asahi Chemical Industry Co., Ltd.  
 (currently Asahi Kasei Corp.)  
 June 2011 Representative Director and President, Asahi Kasei Ability Corp.  
 April 2014 Representative Director and President, Asahi Kasei Amidas Corp.  
 Feb. 2017 Member, Central Labour Relations Commission (current position)  
 June 2022 Director, the Company (current position),  
 Director, The Institute for International Business Communication G  
 (current position)

## Directors / Audit &amp; Supervisory Committee Member

Director  
Audit & Supervisory Committee  
Member**Mitsuhiro Sakizuki**

April 1978 Joined Saitama Bank, Limited (currently Resona Bank, Limited)  
 April 2005 Joined the Company  
 April 2011 Corporate Officer  
 April 2015 Managing Officer  
 June 2017 Director  
 April 2019 Senior Managing Officer  
 June 2020 Director / Audit & Supervisory Committee Member (current position)

Outside Director  
Audit & Supervisory Committee  
Member (Independent)**Ryoji Shimada**

Oct. 1992 Joined Osaka Office of Asahi Shinwa & Co.  
 (currently KPMG AZUSA LLC)  
 May 1997 Registered as certified public accountant  
 Oct. 1997 Joined Tokyo Office of Ota Showa Audit Corporation  
 (currently Ernst & Young ShinNihon LLC)  
 July 2007 Opened Solution Square Corporation, Director (current position)  
 Mar. 2008 Opened Fugen Audit Corporation, Company Representative (current  
 position)  
 June 2022 Director / Audit & Supervisory Committee Member, the Company  
 (current position)

## Corporate Officers

Senior Managing Officers**Yukio Hosaka**Research & Development Division  
Head,  
General Manger of Element  
Development Dept.Managing Officers**Shinichiro Seki**Managing Director of  
Janome Australia Pty. Ltd.,  
Janome New Zealand Ltd.**Hiroyuki Kobayashi**Home Appliance Domestic  
Business Division Head**Shinji Tsunoda**Management Planning Division Head,  
General Manager of Product  
Planning DepartmentCorporate Officers**Hiroshi Ikuta**Home Appliance International  
Business Division Head**Shinichiro Yamamoto**Home Appliance International  
Business Divisional Vice Head,  
General Manager of International  
Business Department I**Satoru Ishikawa**Research & Development  
Divisional Vice Head,  
General Manager of Household  
Equipment Development**Hideki Iwama**Managing Director of  
Janome Europe B.V.,  
Janome Deutschland GmbH**Seiichiro Shitama**Industrial Equipment Sales  
Division Vice Head,  
General Manager of Industrial  
Equipment Sales Department I,  
Equipment Sales Department II,  
Janome Industrial Equipment Taiwan  
Co., Ltd.**Tsugunari Yamada**President & CEO of Janome America, Inc.,  
Janome Canada, Ltd.



Actions taken for Corporate Governance



Janome recognizes upgrading corporate governance and controlling the risk management as well as reinforcing compliance as the crucial management tasks, if we are determined to execute our businesses sustainably to expand our corporate value further. We are committed to take actions to fulfill these tasks.

We understand the corporate governance should function as guide by which we make management decisions that are both transparent and fair, prompt and decisive for Janome to cement sound relationship with each stakeholder including investors to co-create the corporate value. On top of the general recognition of corporate governance as a structure for a private enterprise to avoid risks, to prevent scandals and to enhance transparency, Janome believes that pursuing better corporate governance gives management more incentives to take sound risks, to support our effort for sustainable growth and to realize medium to long term expansion of our corporate value.

Risk management is controlled by the 'Risk Management Committee' which identifies the risks we may face in pursuing sustainable expansion of our corporate value, grasps the potential impact of these risks and prepares measures in advance to prevent, minimize or diversify the losses. Each risk is scrutinized of its probability of occurrence and its potential impact to determine its gravity, according to which preventive measures are elaborated and implemented.

Compliance is required at Janome for observing corporate ethics and social norms not to mention laws and internal regulations. The compliance system is governed by the Compliance Committee, comprised of the directors. Internal Reporting Hotline is set up to ensure organic function of the system for early detection and correction of unfair practices.

Actions taken to strengthen Corporate Governance structure

2022	● Revised policies to determine individual director's compensation package (P.53)
2021	● Introduced policies to determine individual director's compensation package
2019	● Abolished Anti-takeover defense
2017	● Set up Nomination and Compensation Advisory Committee
2016	● Performed Efficiency Assessment of Board of Directors ● Corporate structure changed to Company with Audit and Supervisory Committee
2015	● Document Basic Principles of Corporate Governance
2011	● Set up Risk Management Committee
2010	● Documented Janome Group Code of Conduct
2008	● Set up Internal Audit Department
2007	● Abolished Retirement Benefit System for Directors and Officers
2006	● Documented Basic Policies of Internal Control System ● Set up Compliance Committee and *Internal Reporting Committee
2005	● Set up Personal Data Protection Committee ● Reduced Director's tenure to one year
1999	● Introduced Corporate Officer system
1995	● Set up PL(Product Liability) Committee
1988	● Documented Corporate Mission

Quick reference of our Corporate Governance structure

Institutional design	Company with Audit and Supervisory Committee
Directors	8 Directors, 3 of whom OD *1 4 A/S Com Mem *2, 3 of whom are OD
Director's tenure	Directors: 1year A/S Com mem: 2years
Corporate Officer System	Yes
Optional Advisory Committee	Nomination and Compensation Committee
Accounting Auditor	Ernst & Young ShinNihon LLC
Corporate Governance Report	<a href="https://www.janome.co.jp/ir/pdf/governance_report.pdf">https://www.janome.co.jp/ir/pdf/governance_report.pdf</a>

Note 1: Outside Director  
Note2: Audit / Supervisory Committee Member

Ratio of outside directors

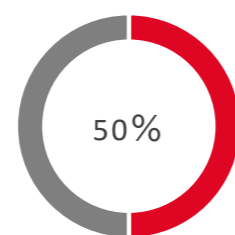

Ratio of female directors

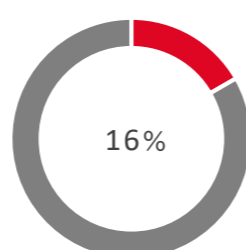

Basic principles of Corporate Governance

Janome is committed to continuously upgrade corporate governance practices, which are indispensable to fulfill its corporate social responsibility by (i) maintaining a fair and sound relationship with various stakeholders, (ii) securing adequacy of business executions and credibility of the financial reporting and (iii) strictly observing relevant laws and articles of incorporation etc.

«Corporate Governance structure flow chart»

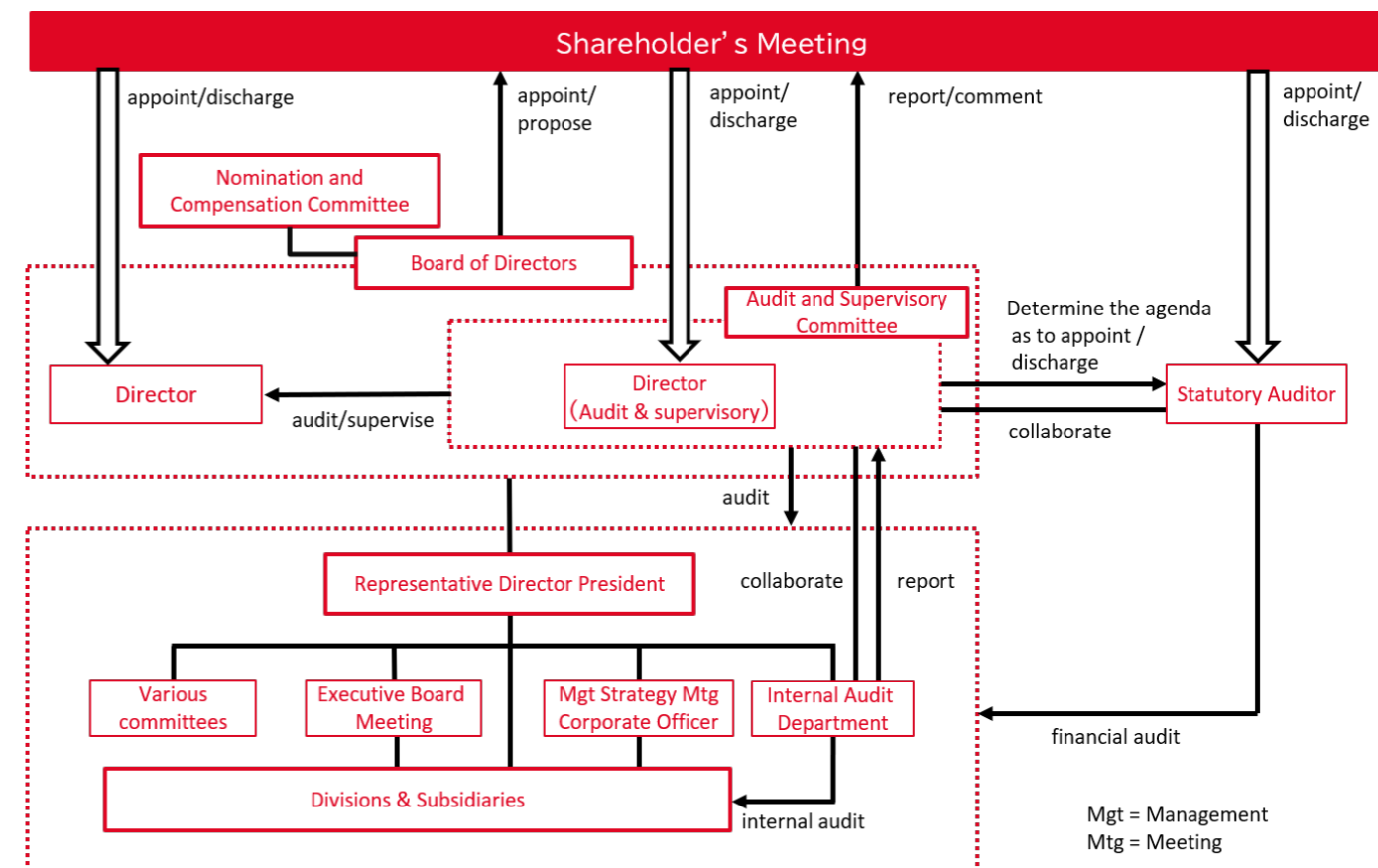

Janome adopted 'Company with Audit and Supervisory Committee' system as its governance structure. The system not only allows the Board of Directors to delegate authority to the Committee to expedite decision-makings and business executions but also reinforces the Board of Directors' authority to supervise and audit, thereby fairness, transparency and efficiency of the management are expected to be enhanced

The Board of Directors authorizes important management matters and supervises the execution of business activities. The current Board of Directors is comprised of nine directors of whom four are outside directors. With the abundant experience and expertise each outside director possesses in corporate management, legal affairs, finance, treasury and/or accounting, they fulfill adequate supervising functions by making comments and proposals to the Board of Directors from their independent and objective perspectives. Three outside directors satisfy Independence Criteria as determined by Janome. They are also registered with the Tokyo Stock Exchange as Independent Directors satisfying the requirements thereof.

The Executive Board Meeting, organized under the Board of Directors, deliberates important management matters and reports the matters of critical importance to the Board of Directors for further deliberation and final determination.

The Audit and Supervisory Committee, by way of exercising its authority to make a statement on voting rights exercised at the Board of Directors as well as the nomination and the compensation of the director candidates at the general meetings of the shareholders etc., audits legality and validity of the decisions of the Board of Directors and the executions of business activities by the executive directors. The committee ensures validity and efficiency of its audit by exchanging comments and insight as well as providing information to the periodical reports made by Internal Audit Department and Treasury Department.

The Corporate Officer system is introduced to separate business executions from their supervision. The system is designed to articulate its authority at the business front and to expedite business executions, thereby efficiency of the supervisory function of the Board of Directors is expected to be enhanced. A Management Strategy Meeting, consisted of the ranks above Corporate Officers, discusses and fully deliberates the pending challenges and issues of each business sector. The Janome Group Presidents meetings are periodically held to exchange information on respective business executions so that the Group as a whole shares the same level of motivation to maintain reasonable and compliant management.

The overseas subsidiaries meetings are also periodically held to exchange and share important matters and to standardize global operations at the appropriate level.

The Nomination and Compensation Advisory Committee is set up as an advisory committee to the Board of Directors, where important matters concerning the nomination and the compensation of the directors, etc. are deliberated and advised to the Board of Directors so that objectivity and transparency of the decisions are warranted.

Name of the institution	Directors
Board of Directors	Directors : Makoto Saito (Chairman), Toshiya Takayasu, Hitoshi Doi, Kazushi Kawaguchi, Takeyuki Oshima, Mitsuhiro Sakizuki Outside Directors: Fumiaki Nakajima, Shoko Sugino, Yasuyo Tanaka, Keizo Tanaka, Ryoji Shimada, Mamoru Sumida
Audit and Supervisory Committee	Director : Mitsuhiro Sakizuki (Commissioner) Outside Directors: Keizo Tanaka, Ryoji Shimada, Mamoru Sumida
Nomination and Compensation Advisory Committee	Directors : Makoto Saito, Mitsuhiro Sakizuki Outside Directors: Fumiaki Nakajima(Commissioner), Keizo Tanaka

**Number of meetings and committees for Fiscal Year 2022**

The Board of Directors assembled 18 times with all the outside directors' attendance, ensured the legality, fairness and efficiency of the director's fulfillment of their duties. The Executive Board Meetings were held 20 times while the Management Strategy Meetings were held 18 times. Audit and Supervisory Committee was held 20 times and conducted strict audit by following the scheduled audit plan. The committee ensured the validity and efficiency of its audit by exchanging comments with and providing information to the periodical reports made by Internal Audit Department and Treasury Department.

The Nomination and Compensation Advisory Committee, an advisory body to the Board of Directors, assembled three times to deliberate on matters of importance concerning the nomination and the compensation of the directors and the corporate officers and advised the Board of Directors on these matters.

**Efficiency Assessment of the Board of Directors**

Janome conducts an annual survey of the directors for the purpose of assessing the efficiency of the Board of Directors and endeavors to improve efficiency thereof by analyzing and assessing the survey results.

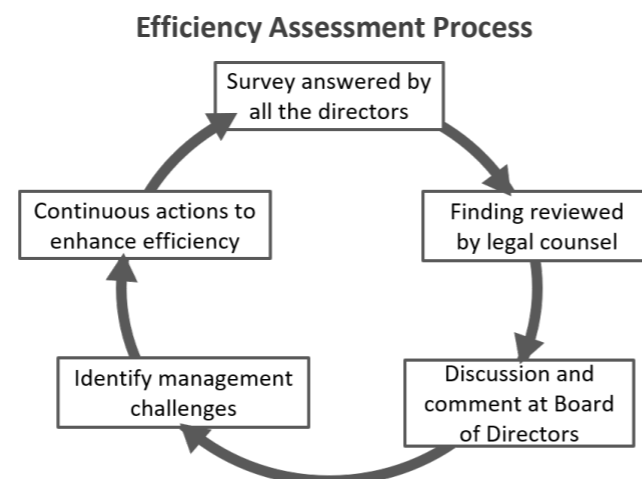

Below is the summary of the fiscal year 2022 survey and findings.

**Survey outline**

Janome Board of Directors in March 2023 conducted a survey along the outline below and had a discussion in May 2023 for the purpose of improving the efficiency of the Board of Directors, based on the survey findings and the recommendations from our legal counsel.

- Focus of the survey structure, operation, role and responsibility of the Board of Directors, its supporting system, self-evaluation of the directors, overall evaluation of the Board of Directors
- Respondents: all the 12 directors including directors of Audit and Supervisory Committee.
- Evaluation system: 4 or 3 point scale evaluation and free comments
- Respondent's name: Anonymous

**Survey findings**

We confirmed that efficiency is maintained at a reasonably adequate level from the findings that the Board of Directors consists of adequate number of persons with balanced diverse backgrounds and that a system is in place to stimulate communications between internal and outside directors, which forms a foundation for adequate discussions by the Board of Directors. On the other hand, While the discussion focused on management strategies and the Mid-term business plans, there was a lack of discussion on the nature of financial strategies with an awareness of the cost of capital, confirming the need for continued discussion and further deepening of such discussions. The Board of Directors will take those survey findings to seriously pursue to increase the efficiency of the Board of Directors.

**Director's nomination policy**

The candidates for the Janome directors are selected from a wide variety of the human assets. After discussion with and advice by the Nomination and Compensation Advisory Committee, final candidates are cautiously deliberated further by the Board of Directors before the nomination. The director candidates of those who are to be the directors of the Audit & Supervisory Committee require the prior approval of the Audit & Supervisory Committee.

An Executive Management member's selection is originated by the Representative Director from among the human assets with potential to contribute to both sustainable growth of Janome and the Group companies and medium to long term expansion of corporate value. The Board of Directors carefully deliberates Representative Director's selection and makes a nomination. In case a director fails to fulfill his responsibility in terms of financial performance, for example, the Nomination and Compensation Advisory Committee deliberates his discharge considering his overall performance and if the committee deems appropriate, may advise the Board of Directors of his discharge.

**Director candidate qualities and capabilities**

1. Persons with abundant expertise and experience to execute and manage the businesses of the Janome Group
2. Persons with thorough understanding of their social responsibilities and missions as a director and sublime self-discipline to accurately and fairly pursue the executions and management of the businesses of the Janome Group.
3. Directors of the Audit & Supervisory Committee should possess capacity to supervise from fair and objective perspective the executive director's business executions thereby contributing to improve soundness and transparency of the management.



**Outside director candidate qualities and capabilities**

- Persons deemed to possess no potential reason to have any conflict of interest with the general shareholders of JANOME Corporation.
- Persons with thorough understanding of their social responsibilities and missions as directors.
- Persons who understand fully the role of the outside directors, possessing the capacity to supervise the internal directors and the management as well as to voice accurate and proper opinions and advice capitalizing on their profound expertise in corporate management, economics, legal affairs, accounting, tax practice and/or audit.
- Outside directors of the Audit & Supervisory Committee should possess the capacity to supervise from fair and objective perspective executive director's business executions thereby contributing to improve soundness and transparency of the management.

**Director's major area of expertise and specialty**

Name	Position at Janome	Type of director		Area of expertise & specialty									
		out	indy	cm	rt	pp	ms	oe	fa	lm	wd		
		*1	*2	*3	*4	*5	*6	*7	*8	*9	*10		
Makoto Saito	President			○	○	○		○					
Toshiya Takayasu	Director & Senior Managing Officer			○				○	○				
Hitoshi Doi	Director & Senior Managing Officer							○		○	○		
Kazushi Kawaguchi	Director & Managing Officer			○	○	○			○				
Takeyuki Oshima	Director & Managing Officer									○	○		
Fumiaki Nakajima	Outside Director	○	○	○					○				
Shoko Sugino	Outside Director	○	○								○		
Yasuyo Tanaka	Outside Director	○	○	○							○		
Mitsuhiro Sakizuki	Audit & Supervisory Committee Member								○	○	○		
Keizo Tanaka	Audit & Supervisory Committee Member	○	○								○		
Ryoji Shimada	Audit & Supervisory Committee Member	○	○							○			
Mamoru Sumida	Audit & Supervisory Committee Member	○						○	○				

	Legend	Full description		Legend	Full description
1	out	outside(director)	6	ms	marketing & sales
2	indy	Independent(director)	7	oe	overseas experience
3	cm	corporate & management	8	fa	finance & accounting
4	rt	research & technology	9	lm	legal matter
5	pp	production & procurement	10	wd	work style reform / D&I

**Major activities of outside directors**

	Name	Number of meetings attended		Major Activities
		Board of Directors	Audit & Supervisory Committee	
Outside director	Fumiaki Nakajima	18/18	—	Capitalizing on his management experience and wide ranging expertise, he advises and makes proposals to the Board of Directors so that validity and adequacy of decision-makings is warranted. As a member of Nomination and Compensation Committee, he voices opinions about these matters, fulfilling his duties to supervise decision-makings and business executions.
	Shoko Sugino	14/14	—	Capitalizing on her professional expertise as practicing lawyer, she advises and makes proposals to the Board of Directors so that validity and adequacy of decision-makings is warranted. They also supervise management and business execution by expressing candid opinions from an independent and objective standpoint.
	Yasuyo Tanaka	14/14	—	Capitalizing on her management experience and wide human resources sector expertise, she advises and makes proposals to the Board of Directors so that validity and adequacy of decision-makings is warranted. They also supervise management and business execution by expressing candid opinions from an independent and objective standpoint.
Outside director of Audit and Supervisory Committee	Keizo Tanaka	18/18	20/20	Capitalizing on his professional expertise as practicing lawyer, he advises and makes proposals to the Board of Directors so that validity and adequacy of decision-makings is warranted. Additionally at regular face to face meetings with the Representative Director he voices his opinions from independent and objective point of view.
	Ryoji Shimada	14/14	14/14	Capitalizing on his professional expertise as certified public accountant, he advises and makes proposals to the Board of Directors so that validity and adequacy of decision-makings is warranted. Additionally at regular face to face meeting with the Representative Director he voices his opinions from independent and objective point of view.
	Mamoru Sumida	17/17	20/21	Capitalizing on his management experience and wide ranging expertise, he advises and makes proposals to the Board of Directors so that validity and adequacy of decision-makings is warranted. Additionally at regular face to face meetings with the Representative Director he voices his.

Note 1. Attendance at the Board of Directors meeting for Ms. Shoko Sugino and Ms. Yasuyo Tanaka is their attendance at the meetings held after they assumed the office on June 24, 2022.

Note 2. Attendance at the Board of Directors meeting and Audit & Supervisory Committee for Mr. Ryoji Shimada and Mr. Mamoru Sumida is their attendance at the meetings held after they assumed the office on June 24, 2022.

**Independence Criteria for Outside Directors**

Janome documented the Independence Criteria for Outside Directors as below to maintain fairness and transparency in enforcing appropriate governance control. The directors satisfying those standards are registered with the Tokyo Stock Exchange as Independent Directors satisfying the requirements thereof.

Directors meeting none of the descriptions below shall be deemed to have adequate independence as outside directors of Janome.

- Any person who used to belong or is currently belonging to JANOME Corporation and/or its consolidated subsidiary, hereinafter referred to as 'the Janome Group Company'
  - This category includes directors, corporate officers, fellows and employees, hereinafter referred to as 'the Business Executor' who used to belong or is currently belonging to the Janome Group Company
- Any Major shareholder of JANOME Corporation and the Business Executor belonging to major shareholder
  - This category includes any shareholder possessing more than 1% of Janome stock with voting rights individually in his own name or collectively with other person(s)'s name(s), hereinafter referred to as 'Major shareholder', and in case such shareholder is an organization, the Business Executor belonging to such organization.

## 3. Any Business Executor belonging to major business partner of the Janome Group Company

- This category includes the Business Executor belonging to major business partner of the Janome Group Company.

Major business partner is defined as a business partner whose annual transaction value with the Janome Group Company exceeds 1% of the consolidated annual sales value of the Janome Group company.

## 4. Any Business Executor belonging to major lender to the Janome Group Company.

- This category includes the Business Executor belonging to major lender, which is defined as a financial institution whose lending balance to the Janome Group Company as of the fiscal yearend of the Janome Group Company exceeds 5% of Janome's consolidated total asset.

## 5. Any certified public accountant belonging to the auditor in charge of accounting audit of the Janome Group Company.

## 6. Any professional such as the consultant, accountant, tax accountant, lawyer, judicial scrivener, patent attorney receiving any compensation or any other benefit with monetary value from the Janome Group Company.

## 7. Any person whose spouse, family member or relative within the second degree of kinship, or cohabitant who meets any of the above descriptions 1 to 6.

## 8. Any person who used to meet any of the above descriptions 2 to 7 within the past five years.

## 9. Any person who is deemed to possess any particular reason to have conflict of interest with the Janome Group Company.

## Director's compensation

Compensation for FYE March 2023 is as below.

Type of directors	Total compensation (in millions of yen)	Total compensation by kind (in millions of yen)		Number of directors in each category
		Fixed compensation	Performance linked bonus	
Directors (excluding Audit & Supervisory Committee Directors and Outside Directors)	116	116	—	5
Audit & Supervisory Committee Directors (excluding Outside Director)	23	23	—	1
Outside Directors	36	36	—	8

Note1. Total amount of remuneration, etc. for each director is not stated because there is no director whose amount paid exceeds 100 million yen.

Note2. The 90th General Meeting of Shareholders held on the 17th of June, 2016 resolved that total annual compensation for directors (excluding Audit & Supervisory Committee director) shall not exceed 240 million yen and the same for Audit & Supervisory Committee director shall not exceed 80 million yen

Note 3. Remuneration for the employee portion of the employees also serving as directors is not to be included in the calculation above. Persons falling in this category do not currently exist in the company.

### Policies to determine individual director's compensation package

Janome reviewed its director's compensation package in terms of further reinforcing its corporate governance structure as well as improving its mid to long term corporate value expansion, and determined by the Board of Directors' resolution to compensate Audit & Supervisory Committee Directors and Outside Directors with fixed salary only. Also resolved there is the revision for the calculation of performance linked bonus. See below the revised policies for your reference.

## (1) Basic policy

- ① Compensation system of Janome directors is structured to assure the sustainable growth of the company as well as to contribute to mid to long term expansion of the corporate value of the company. Actual level of compensation is determined, on top of this structure, by the overall financial results of the company as well as the individual area of responsibility and performance thereof of each director.
- ② Director's compensation consists of a fixed salary and a performance linked bonus as an incentive.
- ③ Individual compensation shall be determined with adequate considerations so that the allocation of the latter is not excessive.
- ④ Maximum amount of aggregate compensation for the non- Audit & Supervisory Committee directors and the same for Audit & Supervisory Committee directors shall each be determined with the resolution by the General Meeting of Shareholders.
- ⑤ The Board of Directors is authorized to determine individual director's compensation within the maximum amount of the aggregate compensation for the non- Audit & Supervisory Committee directors as determined with the resolution by the General Meeting of Shareholders.
- ⑥ The Audit & Supervisory Committee directors shall determine each individual compensation package after deliberation among themselves within the maximum amount of the aggregate compensation for the Audit & Supervisory Committee directors as determined with the resolution by the General Meeting of Shareholders.

## (2) Policy to determine the fixed salary of an individual director, including its calculation method

- ① Representative Director drafts an individual fixed salary considering the individual performance, the contribution to the overall corporate performance, expectation for his or her future performance, years as a director, etc., of the non- Audit & Supervisory Committee directors.
- ② To secure transparency and fairness, said draft is sent to the Nomination and Compensation Advisory Committee, where it is deliberated along with the hearing of Audit and Supervisory Committee.
- ③ The Board of Directors determines the final amount by its resolution.
- ④ The fixed salary portion of an individual director shall be paid regularly in increments within his tenure.

## (3) Policy to determine the performance linked bonus of an individual director, including its calculation method

- ① The performance linked bonus shall be determined in accordance with the guidelines resolved by the Board of Directors and be paid after deliberation by the Nomination and Compensation Advisory Committee. Candidates for the bonus shall include corporate officers and fellows.
- ② The performance linked bonus shall benchmark the non-consolidated net income after tax to boost directors' motivation to improve the fiscal year performance and to achieve numerical management targets. The maximum aggregate remuneration of directors shall remain within 5% of the said benchmark.
- ③ The individual compensation of the non- Audit & Supervisory Committee directors shall be allocated pro rata to the fixed salary amount of each recipient, subject to the Board of Directors' resolution.
- ④ The performance linked bonus shall be paid to the directors, corporate officers and fellows who remain on these positions at the end of the final day of the preceding fiscal year. Actual payment shall be made during a certain period of time or shall not be made at all depending on its inherent nature.



## Basic profit distribution policy

Janome's basic profit distribution policy is to reinforce the sound financial foundation by maintaining a strong equity base at the same time as seeking to maximize the shareholder profit by pursuing to improve capital efficiency.

Target dividend payout ratio to the shareholders is set at 30% of the fiscal year end consolidated net profit attributable to owner's parent, as we determine the actual payout considering overall capital position by taking into account exercising various options including stock repurchase.

### Per share fiscal year end dividend trend

	FYE2020 94 <sup>th</sup>	FYE2021 95 <sup>th</sup>	FYE2022 96 <sup>th</sup>	FYE2023 97 <sup>th</sup>	FYE2024 98 <sup>th</sup>
Dividend (¥)	15	25	40 *1	25	25 (forecast)
Consolidated Net Profit (¥in mil) belonging to the shareholders of the parent company	424	3,945	2,549	△393	1,500 (forecast)
Payout Ratio	68.4%	12.2%	30.3%	—	32.2% (forecast)

※Note1: 15 yen of the dividend was paid out as interim dividend in celebration of the 100th Anniversary since founding.

Note2: On August 9, 2023, the Company resolved and disclosed the repurchase of its own shares, which has been implemented since then.

## Adequate Disclosure

Janome recognizes the importance of prompt and accurate disclosure to all of our stakeholders including customers, shareholders, investors and business partners so that we retain trust from society and continue to be rewarded with the proper market valuation that we deserve.

In this context, in addition to timely and adequate disclosures dictated by relevant laws and regulations such as Company Law, Financial Instrument and Exchange Law and Timely Disclosure Rules of the Tokyo Stock Exchange, we are making, in strict observance of the Fair Disclosure Rule, active and fair disclosure of all the information including negative ones, which we trust is of use for all the stakeholders to understand the Janome Group Company better.

In the FYE March 2023, we issued in November Shareholder Newsletters that summarized the combined financial results, etc. In October, the JANOME REPORT, a comprehensive summary of Janome was issued.

Financial results briefings we have regularly conducted for the media, securities analysts and institutional investors had to be cancelled for FYE March 2023 due to the Covid-19 pandemic. We instead uploaded financial results as well as Investor Relations information on our website in our continued efforts to expand our disclosure contents.

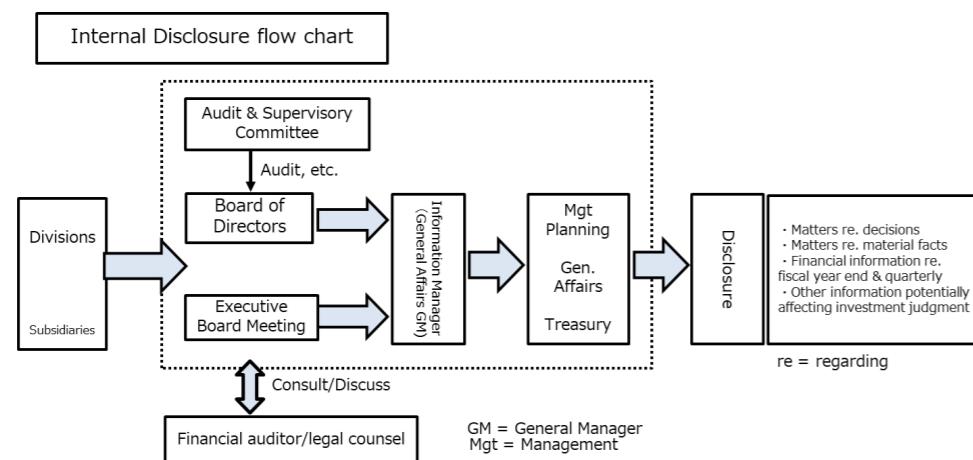

## Risk management

### Risk management structure

The Risk Management Committee is organized to identify and proactively deal with the potential risks Janome and the Group Companies may be involved in and to minimize its impact, in case the risk is materialized, for our swift recovery back to the normal course of the business. The committee is chaired by the Division Director with the members consisting of those above the manager ranks. It is responsible for collecting information, developing the risk management systems and training employees. The committee monitors and conducts risk evaluation of Janome and the Group Companies, with whom it shares these findings so the risk shall be monitored and reduced. The Compliance Committee and the other committees, organized for each purpose as described below, collectively with the Risk Management Committee compose the system to monitor and control the overall risk of the Janome Group Companies.

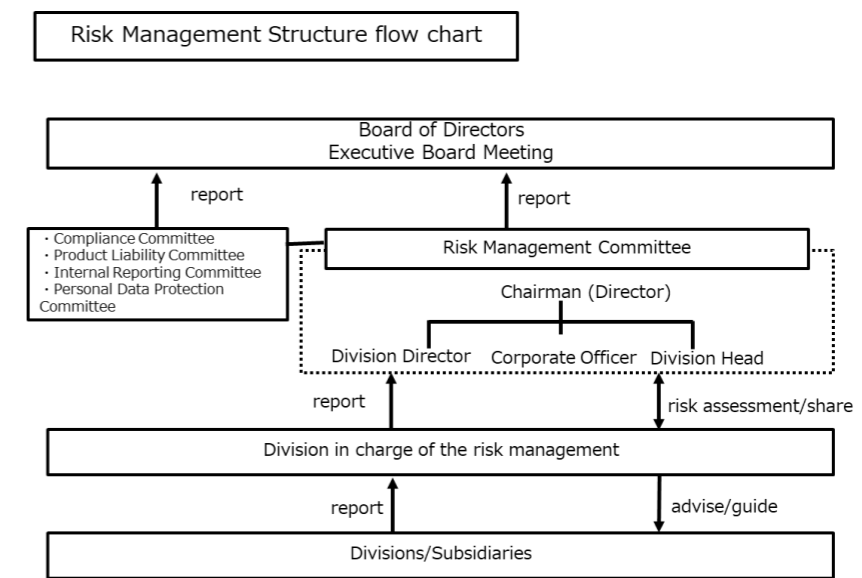

#### <Sustainability Advancement Committee>

The Division Director chairs and Outside Director MC's the committee with the participation of Division General Managers. The committee deliberates material sustainability matters, identifies the challenges, targets and strategies and assesses the performance thereof.

#### <Compliance Committee>

The Division Director chairs the committee with the participation of division corporate officers. The committee deliberates important compliance matters.

#### <Internal Reporting Committee>

The Division Director chairs the committee with the participation of the outside legal counsel. The committee promptly deliberates and processes an internal report in strict accordance with the internal rules and regulations.

#### <Product Liability (PL) Committee>

The Division Director chairs the committee with the participation of the relevant division/department head in charge. The committee holds a monthly meeting to deliberate product safety issues.

#### <Personal Data Protection Committee>

The Division Director chairs the committee with the participation of certain members across Janome. The committee develops the personal data protection plan in accordance with the internal rules and conducts audit and internal training for the employees.

### Business Continuity Plan (BCP)



Janome documented the Business Continuity Plan in preparation for such emergency situations as a massive earthquake strike with its epicenter right beneath the Tokyo Metropolitan Area, an outbreak of infectious disease such as the New Coronavirus and an internal information system breakdown. The plan defines how precautionary measures should be prepared and deliberated as well as what actions and procedures should be followed upon the actual disaster situations.

Additional measures developed to secure the safety of the employees in emergency situations are (1) Disaster Response Manual laying out the points to remember and the basic responses to take in disaster situations, (2) Emergency Essentials Takeout Box containing minimum supply of essentials, delivered to each and every employee on top of an additional supply of essentials and protective goods stored at appropriate locations and (3) Employee Safety Confirmation System, periodically tested for its validity and employee's awareness of risk preparation.

Major business risks

In reference to the risks which may potentially impact its management results, stock price and financial positions, Janome separately discloses the 'individual risks' inherent to particular businesses and the 'universal risks' prevalent in all its businesses in its Securities Reports and will aim to avoid the occurrence of those risks and to minimize the impact at the time of their occurrences. Listed below are the 'universal risks'.

Risks and its impact
<p>【Currency fluctuation risk】 : Active overseas business expansion of the home appliance and the industrial equipment has kept the overseas sales ratio to consolidated total sales at around 70%. While currency fluctuation risk is minimized by active use of forward contracts as well as foreign currency nettings between Janome and its overseas subsidiaries, we cannot totally escape the adverse effects of currency fluctuation on the Janome Group business performance as the substantial portion of the overseas sales are transacted in the local currencies.</p>
<p>【Purchasing cost increase risk】 : Coupled with the efficient production allocation among the production facilities in Japan, Taiwan and Thailand reflecting the changes in global trend of demand, the global parts procurement helps reduce and stabilize overall purchasing costs. While the Production Management Division supervises both domestic and foreign production facilities to continuously strive to minimize the impact of increases in purchasing cost, increase of raw materials such as iron, aluminum, copper and resin may adversely impact the Group business performance.</p>
<p>【Country risk】 : Each country where we possess a production facility as well as sales/distribution network is exposed to the potential changes in the political system, legal and regulatory environment, political climate and economic conditions, occurrence of earthquakes, typhoons and other natural disasters, outbreak of war and terrorist attacks which may disrupt the continuation of business activities and adversely impact the Group business performance.</p>
<p>【Quality control risk】 : Janome products are backed by a long history of manufacturing know how. The PL (Product Liability) Committee is set up to monitor the safety of our products, and any issues identified are deliberated at a monthly meeting. The Quality Assurance Department leads the companywide activities to promote quality control across entire Janome Group and strives to grasp the progress on quality audit and pending quality issues of the sewing machines and the industrial equipment produced by Janome and the Group Companies in both domestic and overseas markets. Should a serious quality issue arise, the Group business performance may be exposed to the adverse impact of having to sustain the cost associated with recall of the product and/or damage to the brand.</p>
<p>【Market environment change risk】 : Whilst we cannot escape battling against the competitor threats in our effort to maintain and expand our business, we continuously strive to improve the quality of our products and services by combining our resources and strength of development, production and sales to withstand and cope with such threat. Substantial changes in the market environment, however, such as steepening competition may adversely impact the Group business performance.</p>
<p>【Interest rate change risk】 : Some of our interest bearing debt is subject to interest rate changes. Rise in the market interest rate shall increase our interest payment burden and may adversely impact the Group business performance and financial positions.</p>

Compliance

'The Janome Group Code of Conduct' is documented as the basic principles of compliance of the Janome Group companies along which each and every director and employee must conduct sound business practices with sublime ethical standards and endeavor to achieve sustainable growth as well as to expand corporate value.

Compliance promotion system

The Company has established a Compliance Committee, chaired by a director, for the purpose of ensuring and promoting compliance. The committee is responsible for the development of the Group's compliance system, education, and collection of information. In addition, in accordance with internal reporting regulations, the Company has established an "Internal Reporting Hotline" with an outside attorney as a contact person for consultation regarding organizational or individual violations of laws, regulations, etc., or misconduct. All directors, officers, employees, and retired employees of domestic group companies, including temporary employees, can report anonymously by telephone, e-mail, fax, in writing, or in person. Whistleblowers are protected from demotion, salary reduction, dismissal, or other disadvantageous treatment in accordance with the Whistleblower Protection Act and the Company's Whistleblower Handling Regulations, and adequate follow-up is provided to protect whistleblowers. We strive to prevent compliance violations by promptly investigating reports and taking appropriate measures and countermeasures.

Compliance promotion activities

The Company has established the "Group Compliance Regulations," and "Compliance Committee" consisting of the Internal Audit Dept, as the executive office plays a central role in ensuring the Group's Compliance. Major activities include distribution of e-mail magazine named compliance news letters, distribution of compliance handbooks, holding seminars, and conducting awareness surveys and questionnaires to raise compliance awareness.



Compliance Newsletter

Personal Date Protection

Janome thoroughly protects and controls personal data in strict observance of the Personal Data Protection Policy. The Personal Data Protection Committee leads the activities based on this policy to establish 'The Personal Data Protection Plan' and conducts audit and internal education so that 'proper personal data protection' as defined in 'The Janome Group Code of Conduct' is achieved.

In FY2022, the Personal Date Protection Committee hosted an in-house training session on the protection of personal information. The participants watched a DVD with a case study of the leakage of confidential company information due to an erroneous e-mail transmission, which provided an opportunity to reconsider the handling of confidential information, including personal information.





### Need to structure a governance system geared ESG management

A private enterprise used to be able to focus its effort on the pursuit of maximizing its business profit. Time has changed rapidly until recently, when it became indispensable for a private enterprise to not only pursue its business profit but also to act in an environmentally friendly manner as well as responsibly as a corporate citizen in its business activities involving its environment and society, if it intends to expand its corporate values continuously for mid to long term with sustainable growth. There is also an immediate need to structure a solid governance system that effectively monitors the corporate behavior. Janome has proactively progressed to implement governance reform measures to suit the changing business environment.

Janome replaced in 2016 its corporate structure with a Company with Audit and Supervisory Committee in time in the year succeeding to 2015, when the Corporate Governance Code was publicly announced and the revisions to the Companies Act were enforced. Janome established the Audit and Supervisory Committee comprised of multiple independent outside directors and an outside director, as well as full time executive directors well versed in the actual business executions of the Janome Group, so that audit structure is effectively reinforced. In 2017 the Nomination and Compensation Committee was set up to secure transparency and

### Outside director Keizo Tanaka

validity in the nomination and compensation of its directors, followed by the participation of an independent outside director in 2019 who brought with him to the committee a wealth of knowledge and expertise. Janome proceeded to further reinforce its governance structure control in preparation for the successful entry into the Prime Segment in April 2022 Tokyo Stock Market restructuring.

#### Need Effective governance execution and the role of independent outside director

Janome Audit and Supervisory Committee, in close cooperation with Accounting Auditor and Internal Audit Department, examines abundant and detailed information on the business executions of the Janome Group offered by full-time Audit and Supervisory Committee director. The committee goes so far as to directly request a face to face meeting with the business execution staff in charge of the matters of a particular concern. Speaking as someone who assumed a position as an independent outside director with legal qualifications, active exchange of opinions are being conducted with diverse perspectives of the members of Audit and Supervisory Committee, on broad issues including internal control, compliance, validity of financial data, risk management issues elaborated at various committees and governance matters concerning nomination and compensation. Additionally, regular meetings are in place to exchange views with independent outside directors, with strict exclusion of the members of Audit and Supervisory Committee so the outside directors are well informed with objective views as to where the company stands in various management matters.

I believe that current Board of Directors, entrusted by shareholders to possess corporate management expertise, is strongly requested to elaborate essentially critical management matters of immediate concern.

The Board should further maintain its effective authority to be able to supervise the level of fairness and validity in its decision makings. Janome Board, while demonstrating its perfect fit to the characteristics detailed above, conducts debate and deliberation on management matters with immediate concern in a relaxed atmosphere that encourages the participants including outside directors to express there views without reservations.

As a practicing lawyer with rich experience and expertise in legal matters, I am making a point of actively expressing my views and observations especially on such matters as optimization of business process execution and risk control at the Board meeting.

I was appointed a member of the Nomination and Compensation Advisory Committee in June 2022 and have been involved in maintaining adequacy for the nomination and compensation standards of the directors. Janome got off to a fresh start after passing in 2021 its milestone 100th anniversary and successfully entered into the Prime Segment of Tokyo Stock Exchange in April 2022. On top of the management strategies with proactive insight into the future, I believe Janome is required to structure a governance system, built and honored along the principles of 'Independence and Diversity' and to constantly be engaged in fostering and training human 'asset' to become candidates for the future management team who will be steering the company to the right directions in the future, if Janome seeks to expand its medium to long term corporate value along the line with the mission statement of ESGs. While corporate management judgments never cease to be challenging in a world with complex societal and circumstantial changes, I intend as always to dedicate my resources to contribute to Janome's quest to secure adequacy and validity in its business management



### Efficiency Assessment of the Board of Directors and the need to expedite female employees advancement

Directors are expected, as representatives of the Board, to be actively involved with corporate decision makings of the matters including fundamental corporate principles, as well as to monitor the business executions by each business unit. Collecting pertinent information It is imperative to collect pertinent information to fulfill the tasks for outside directors who are mostly away from the corporate premises.

Let me briefly describe what is happening at Janome Board of Directors. The Board deliberates the matters dictated by relevant laws as well as those defined by the corporate rules to require the resolutions of the Board. Corporate decisions are made only after substantive deliberations thereof. More than ten meetings of the Board of Directors are held in a year. Every one of the 18 organized in the fiscal year ended March 2023, is preceded by reference materials, supported by detailed explanations of the management's intentions as well as the background and pertinent data that are prepared by the secretarial office of the Board and sent to each director well in advance of the Board meeting, so that all the participating directors will come to the meetings with thorough understanding of the matters on the agenda. It is this well-considered support that drives tremendously thorough deliberations at the meetings.

### Outside director Shoko Sugino

Some of those matters deemed critically important to the company are shown to the participant well in advance and are discussed and deliberated at multiple meetings before the corporate decisions are made.

Typical Board of Directors meetings begin with the presentation by the business unit staff in charge of the matter, followed by questions and comments by the Board members in a relaxed atmosphere stimulating unbiased and unrestrained discussion by the members.

Descriptions above support my judgement of the Board of Directors at Janome as effectively functioning conference body.

Current Board of Directors consist of 12 members, of which 6 are outside directors, joined by two female directors since June of 2022, who have had no involvement with Janome until then.

Female managers' ratio at Janome as of the Fiscal Year 2021 stands at 19.4%, driving home the message to the management that advancing women to major roles is one of the most urgent goals to achieve, for which various measures and programs are continuously introduced to create better working environment that fits female career advancement. I am hoping to see the day sooner than later, when female staff, having made substantial contributions Janome in their fields of expertise, will make it to the first female director at Janome.

#### Reinforcing the governance structure for further expansion of the corporate value

Audit and Supervisory Committee comprised of Audit and Supervisory Directors is responsible at Janome for monitoring and supervising the legitimacy of its business executions so that the company retains legitimacy in its corporate dealings, some records of which are shared with the directors who are not Audit and Supervisory Committee Director, sharing of which seems a little extraordinary.

It is, however, the very mechanism, pointed out earlier in this text, to provide the vibrant and practical discussions and elaborations of the proposals at the Board meetings. It also supports my belief that Janome's governance system is established on the multi-layered support.

I believe the Board of Directors should continue not only, in what is called "the defensive mode" to ascertain the legitimacy and compliance of the corporate decisions and to monitor its management decisions, but also to guide the ultimate mission of a private enterprise of expanding its corporate values.

We are behind budget mostly in achieving the numerical targets in terms of business productions for the 2nd year of Reborn 2024, our current Mid-term Business Plan, due to the adverse business environment affected by the geo-political risk and the delay in recovery of the global economy. Every expertise, accumulated over a hundred year's history as a leading household sewing machine maker-vendor, must now be exhausted to make it through the current hardship.

One thing we rediscovered along the way is the benefit of having in-house both the development-production with proven technological strength as well as the distribution network with global coverage and marketing expertise. This enables our development department to identify what our sewing machine users are really looking for in this rapidly changing market demands, as well as what and how they can be satisfied by the actual features and applications of the sewing machines that satisfy what the users really wanted. Janome should be able to continue producing the sewing machines that satisfy the changing sewing demands of the times with the proven technological strength. This unique mix of manufacturing and distribution should continue to support sustainable growth of the sewing machines business.

Other businesses of Janome, including industrial equipment and IT related businesses, though explosive expansion may be difficult to achieve, those staff involved in the businesses are highly motivated (to grow them into something meaningful).

I would like to end my note by showing my resolution that I will contribute whatever possible to the sustainable growth of Janome.



## Janome America held new product launches in seven cities

For nine days from August 3 to 11, 2023, Janome America, Inc. toured Montvale, New Jersey; Chicago, Illinois; and five other cities for a total of seven cities to hold "Launch Across America," a new product launch showcase for dealers. A total of 439 dealers attended the event, where the new models "Horizon Memory Craft 9480QC Professional," "Horizon Memory Craft 9410QC," "Continental M8 Professional," and "Continental M6" were unveiled. The training session, which included a demonstration of the A.S.R. function\*, a key selling point of the new models, was very well received by the attendees, who were impressed by the high quality, including ease of use.



Horizon Memory Craft 9480QC Professional



Continental M8 Professional



"Launch Across America" in Chicago, U.S.



Free-motion with A.S.R.function\*

\* A. S. R. function: Stitch regulation system that guarantees perfectly equal stitches when free-motion quilting.

### TOPICS

#### Release of "JANOME Sewing Machine How-to-Use BOOK" (April 24, 2023)

The first Janome sewing book, full of sewing machine know-how and techniques that we have cultivated since our establishment in 1921, is now available published by Boutique-sha Co., Ltd. "JANOME Sewing Machine How-to-Use BOOK" is a sewing book that solves problems and concerns about sewing machines, such as "I have a sewing machine but only use limited functions" or "I want to buy a sewing machine but I am not sure if I can master all the functions". This book introduces easy-to-make sewing works through the one-week lifestyle of a girl who loves sewing, and at the same time, introduces works that will improve her daily life. Recipes are accompanied by process photos and video explanations. We hope that this book will help you discover the charm of the sewing machine once again.



## "Upcycling" initiatives using sewing machines

JANOME holds many workshops throughout the year to promote the fun of handcrafting using sewing machines and at the same time, to expand and improve brand awareness. Sewing machines are used for handmade remaking and reuse, and are a useful "sustainable" product. We hope that sewing machines will make upcycling more familiar to people. We held collaborative workshops that transcended the boundaries of the industry.

\*upcycling...The act of taking something no longer in use and giving it a second life and new function.

arflex × JANOME

### "Tote bag made with furniture strips" @arflex ReStore

At the store of arflex, an interior brand that develops original Japanese furniture while inheriting Italian refinement, we produced tote bags using scraps that are inevitably left over in the process of making sofas and chairs. This was an opportunity for customers who do not usually have the chance to touch a sewing machine to experience the fun of making things with a sewing machine and the process of transforming scraps into "works of art" by using high-quality furniture as a test piece.



Chikusen × JANOME

### Sustainable Living Proposal: "Use good things for a long time" @ Bobinage stores

A workshop was held to create one-of-a-kind original works of art from non-standard yukata fabrics, which are produced in the process of fabric production for the yukata brand Chikusen, and which do not appear as official yukata products. The workshop was held in collaboration with two long-established companies: which was founded in 1921 as Japan's first domestic sewing machine manufacturer and has contributed to the improvement of society and culture as a leading company in the industry, and the yukata brand Chikusen, which has continued manufacturing unchanged since its establishment in the Edo period, when people used things with care in a "recycling-oriented society. The two long-established companies cooperated through workshops to convey the value of cherishing and using "good things for a long time" in this age of mass production and mass consumption.

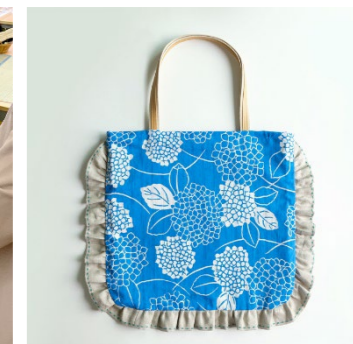
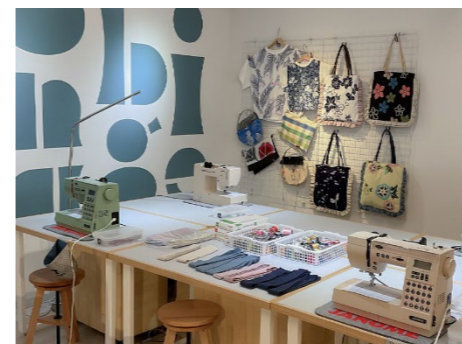



## JIE-USA Exhibits at THE ASSEMBLY SHOW 2022

Rosemont (Chicago), Illinois, USA, October 25-27 2022

Janome Industrial Equipment USA (JIE-USA) introduced our newest products to customers from the US and several other countries at THE ASSEMBLY SHOW an international exhibition of assembly-line related equipment with over 250 exhibiting companies. The tightening, JR3403 Desktop Robot for screw Type Two Hand Switch Model servo press, with working demonstrations showing how to use our products for assembly applications.



J3353T Twin Table Desktop Robot With an ASG brand Electric screwdriver

JR3403 Desktop Robot with a Visco Tec brand 2 component dispenser

JPT0505 Servo Press with barcode reader for tracking work serial numbers

## JIE Exhibits at the 37<sup>th</sup> INTERNEPCON JAPAN

Tokyo Big Sight, January 25-27, 2023

Janome Industrial Equipment exhibited at INTERNEPCON JAPAN, one of largest exhibitions in Asia featuring the latest manufacturing and packaging technologies for multifunctional high performance electronics,



Press fit equipment

Depaneling Robot

## Consolidated Financial Highlights

Net sales • Operating income to net sales ratio (Operating margin) ※1

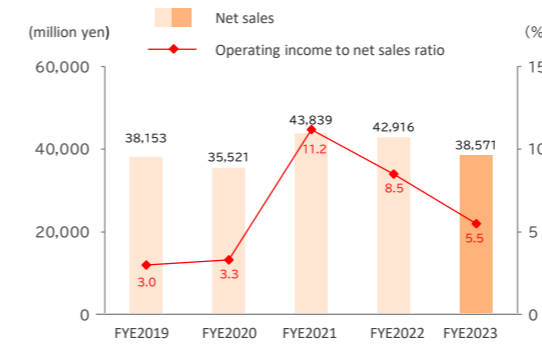

Total asset • Equity ratio

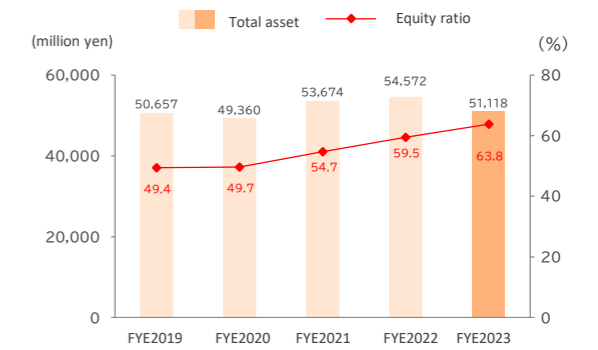

Total asset • Return on ordinary income (ROA) ※2

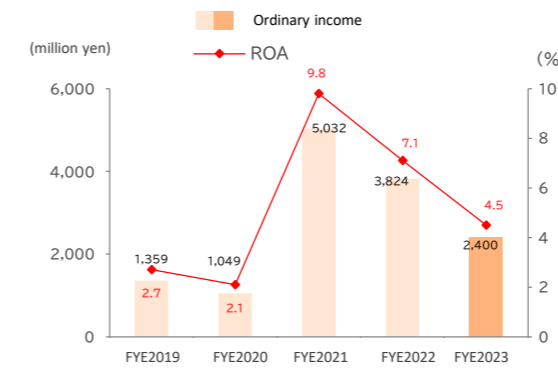

Profit attributable to owners of parent • Return on equity ratio (ROE) ※3

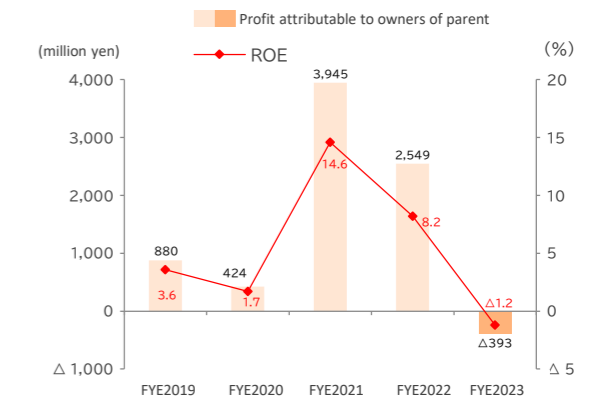

Interest bearing debt • Interest bearing debt ratio ※4

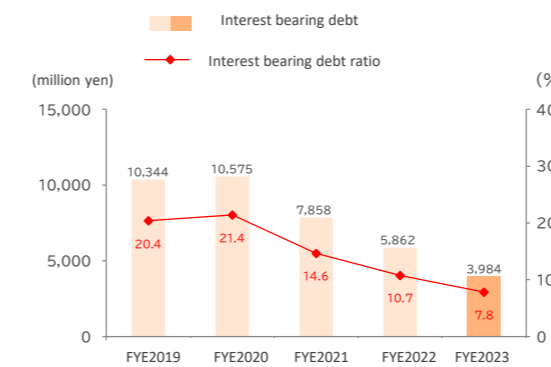

Cash flow factor analysis

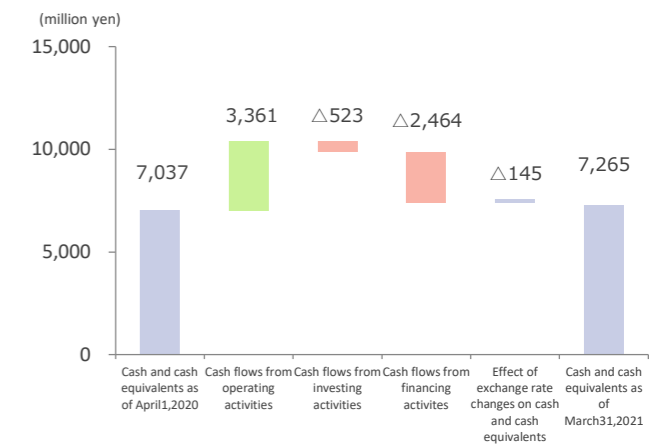

※1 Operating income to net sales ratio = (Operating income)÷(Net sales)×100  
 ※2 Return on asset ratio (ROA) = (Ordinary Income)÷(Total assets)×100  
 ※3 Return on equity ratio (ROE) = (Net income)÷(Equity)×100  
 ※4 Interest bearing debt ratio = (Interest bearing debt)÷(Total assets)×100



## Consolidated Financial Data for the past 11 fiscal years

(Unit: million yen)

Financial Highlights	FY 2012	FY 2013	FY 2014	FY 2015	FY 2016
	[FYE Mar2013]	[FYE Mar2014]	[FYE Mar2015]	[FYE Mar2016]	[FYE Mar2017]
Net sales	38,652	44,696	46,019	42,661	38,855
(Overseas sales ratio)	66.0%	69.6%	71.0%	68.6%	66.0%
Gross profit	15,215	17,266	17,704	17,698	16,804
Operating income	1,727	2,905	2,961	2,466	2,477
Ordinary income	455	2,353	2,711	2,646	2,137
Profit attributable to owners of parent	88	1,460	1,860	1,548	1,607
Capital expenditure	750	716	1,186	1,118	363
Depreciation	1,013	1,119	1,199	1,504	1,423
Research & development	1,189	1,258	1,359	1,462	1,426
<b>Financial Position</b>					
Total asset	50,183	51,409	54,054	51,240	52,052
Net asset	16,373	18,117	21,696	21,949	23,941
Equity	15,835	17,465	20,941	21,184	23,098
<b>Financial benchmark</b>					
Equity to asset ratio	31.6%	34.0%	38.7%	41.3%	44.4%
Return on equity(ROE)	0.6%	8.8%	9.7%	7.4%	7.3%
<b>Cash flow situation</b>					
Net cash from operating activities	636	3,801	2,386	2,256	2,239
Net cash from investing activities	△1,319	△654	△1,664	△752	△625
Free cash flow	△683	3,147	722	1,504	1,614
Net cash used for financing activities	△627	△2,059	△1,406	△1,399	△1,010
<b>Per share date</b>					
Equity per share (EPS)	Yen 819.12	Yen 903.42	Yen 1,083.27	Yen 1,095.86	Yen 1,194.87
Net income per share	Yen 4.56	Yen 75.56	Yen 96.25	Yen 80.11	Yen 83.14
Dividend per share (DPS)	Yen 0	Yen 0	Yen 0	Yen 0	Yen 10

(Unit: million yen)

	FY 2017	FY 2018	FY 2019	FY 2020	FY 2021	FY 2022
	[FYE Mar2018]	[FYE Mar2019]	[FYE Mar2020]	[FYE Mar2021]	[FYE Mar2022]	[FYE Mar2023]
Net sales	40,778	38,153	35,521	43,839	42,916	38,571
(Overseas sales ratio)	65.9%	66.2%	66.1%	69.0%	73.2%	70.4%
Gross profit	16,125	14,945	14,272	18,494	17,332	16,146
Operating income	2,075	1,150	1,158	4,931	3,659	2,120
Ordinary income	2,110	1,359	1,049	5,032	3,824	2,400
Profit attributable to owners of parent	1,391	880	424	3,945	2,549	△393
Capital expenditure	611	821	709	439	775	574
Depreciation	1,369	1,355	1,407	1,103	1,117	1,133
Research & development	1,428	1,470	1,384	1,438	1,435	1,466
<b>Financial Position</b>						
Total asset	51,009	50,657	49,360	53,674	54,572	51,118
Net asset	25,172	25,873	25,381	30,316	33,428	33,364
Equity	24,310	25,020	24,550	29,359	32,475	32,616
<b>Financial benchmark</b>						
Equity to asset ratio	47.7%	49.4%	49.7%	54.7%	59.5%	63.8%
Return on equity(ROE)	5.9%	3.6%	1.7%	14.6%	8.2%	△1.2%
<b>Cash flow situation</b>						
Net cash from operating activities	2,882	2,073	1,512	6,475	219	3,361
Net cash from investing activities	△701	△1,108	△677	△648	150	△523
Free cash flow	2,181	964	834	5,826	369	2,837
Net cash used for financing activities	△2,709	△943	△298	△3,161	△3,368	△2,464
<b>Per share date</b>						
Equity per share (EPS)	Yen 1,257.54	Yen 1,294.30	Yen 1,269.95	Yen 1,518.73	Yen 1,679.93	Yen 1,687.25
Net income per share	Yen 71.98	Yen 45.54	Yen 21.94	Yen 204.12	Yen 131.89	Yen △20.34
Dividend per share (DPS)	Yen 10	Yen 15	Yen 15	Yen 25	Yen 40※	Yen 25

※15yen paid in mid-term to celebrate its centenary

## Consolidated Balance Sheets

(Unit: million yen)

	FY 2021 [FYE Mar2022]	FY 2022 [FYE Mar2023]		FY 2021 [FYE Mar2022]	FY 2022 [FYE Mar2023]
<b>&lt;ASSETS&gt;</b>			<b>&lt;LIABILITIES&gt;</b>		
<b>Current assets</b>			<b>Current liabilities</b>		
Current assets	7,509	7,336	Notes and accounts payable	2,492	1,836
Cash and deposits	7,654	6,571	short-term loans payable	5,862	3,984
Notes and accounts receivable-trade	7,685	6,482	Income taxes payable	1,266	136
Merchandise and finished goods	641	834	Provision for bonuses	618	567
Work in process	3,959	3,933	Provision for director's bonuses	131	-
Raw materials and supplies	620	849	Other current liabilities	2,525	3,285
Other	△ 300	△ 296	Total current liabilities	12,897	9,809
Total current assets	27,771	25,710	<b>Fixed liabilities</b>		
<b>Fixed assets</b>			Deferred income taxes for revaluation	3,352	3,107
Tangible fixed assets			Net defined benefit liability	4,172	3,836
Buildings and structures(net)	5,344	4,977	Other fixed liabilities	721	1,001
Machinery, equipment and vehicles(net)	980	864	Total fixed liabilities	8,247	7,944
Land	13,863	12,921	TOTAL LIABILITIES	21,144	17,754
Construction in progress	30	55	<b>Net Assets</b>		
Other tangible fixed assets(net)	1,375	1,783	capital stock		
Total tangible fixed assets	21,593	20,602	Shareholders' equity Capital stock	11,372	11,372
Intangible fixed assets			Capital surplus	-	0
Other intangible fixed assets	684	644	Retained earnings	13,447	12,156
Total intangible fixed assets	684	644	Treasury stock, at cost	△ 325	△ 325
Investments and other assets			Total shareholders' equity	24,495	23,204
Investment securities	1,444	1,504	Other comprehensive income		
Deferred tax assets	2,362	1,822	Valuation difference in other marketable securities	89	136
Other	752	845	Land revaluation difference	6,562	6,977
Allowance for doubtful accounts	△ 37	△ 12	Foreign currency conversion adjustments	1,460	2,159
Total investments and other assets	4,523	4,160	Adjustment of defined benefit plans	△ 133	139
Total fixed assets	26,800	25,407	Total other comprehensive income	7,980	9,412
Total Assets	54,572	51,118	Non-controlling interests	952	747
			Total Net-Assets	33,428	33,364
			Total Liabilities and Net Assets	54,572	51,118

## Consolidated Statement of Income

### Consolidated Statements of Comprehensive Income

(Unit: million yen)

	FY2021 [FYE Mar2022]	FY2022 [FYE Mar2023]		FY2021 [FYE Mar2022]	FY2022 [FYE Mar2023]
Net sales	42,916	38,571	Profit(△)	2,547	△ 582
Cost of sales	25,584	22,425	Other comprehensive income		
Gross profit	17,332	16,146	Valuation difference on available-for-sale securities	△ 28	46
Sales, general and administrative expenses	13,672	14,025	Foreign currency translation adjustment	1,335	720
Operating income	3,659	2,120	Adjustment of defined benefit plans	81	272
Non-operating income			Total other comprehensive income	1,388	1,039
Interest income	3	12	Comprehensive income	3,936	457
Dividend income	46	74	Comprehensive income attributable to:		
Exchange rate gains	124	184	owners of parent	3,909	624
Other	138	191	non-controlling interests	26	△ 167
Total non-operating income	313	463			
No-Operating expenses					
Interest expenses	70	78			
Other	78	104			
Total non-operating expenses	148	183			
Ordinary income	3,824	2,400			
Extraordinary profits					
Gain on sales of investment securities	64	1			
Gain on sales of fixed assets	22	7			
Total extraordinary profits	87	8			
Extraordinary losses					
Loss on business restructuring	-	1,816			
Loss on sales and retirement of noncurrent assets	54	163			
Impairment loss	33	51			
Total extraordinary losses	88	2,031			
Income before income taxes	3,823	377			
Income tax, resident tax and business tax	1,652	754			
Income tax adjustment	△ 375	205			
Total taxes	1,276	960			
Profit(△)	2,547	△ 582			
Profit attributable to non-controlling interests(△)	△ 2	△ 189			
Profit attributable to owners of parent(△)	2,549	△ 393			



# Consolidated Statement of Cash Flows

(Unit: million yen)

	FY2021 [FYE Mar2022]	FY2022 [FYE Mar2023]
<b>Cash flows from operating activities</b>		
Income before income taxes	3,823	377
Depreciation	1,117	1,133
Loss on business reorganization	-	1,816
Impairment loss	33	51
Increase/ (decrease) in allowance for doubtful accounts	△ 26	△ 48
Increase/ (decrease) of employees retirement benefits	4	△ 458
Interest and dividend income	△ 50	△ 87
Interest expenses	70	78
(Increase)/ decrease in accounts receivable	△ 165	963
(Increase)/ decrease in inventories	△ 2,343	1,479
Increase/ (decrease) in accounts payable	△ 728	△ 296
Other	△ 255	348
Sub total	1,480	5,360
Interest and dividends received	50	85
Interest paid	△ 70	△ 78
Income taxes paid	△ 1,242	△ 2,006
Net cash generated by operating activities	219	3,361
<b>Cash flows from investment activities</b>		
Payments into time deposits	△ 216	△ 0
Proceeds from withdrawal of times deposits	894	188
Purchase of investment securities	△ 598	-
Proceeds from sales of investment securities	600	-
Purchase of property, plant and equipment	△ 775	△ 574
Purchase from sales of property, plant and equipment	221	21
Purchase of intangible assets	△ 59	△ 88
Other	83	△ 70
Net cash generated by investing activities	150	△ 523
<b>Cash flows from financing activities</b>		
Net increase/(decrease)in short-term borrowings	△ 2,384	△ 1,728
Cash dividends	△ 768	△ 483
Cash dividends paid to non-controlling interests	△ 31	△ 37
Other	△ 184	△ 215
Net cash used for financing activities	△ 3,368	△ 2,464
Effect of exchange rate changes on cash and cash equivalents	50	△ 145
Increase/(decrease) in cash and cash equivalents	△ 2,947	227
Cash and cash equivalents at beginning of period	9,985	7,037
Cash and cash equivalents at end of period	7,037	7,265

# Company Overview

Company Name	JANOME Corporation
Founded	October 1921
Incorporated	June 1950
Head Office	1463 Hazama-machi, Hachioji, Tokyo, Japan
Paid-in Capital	11,373 million yen (as of March 31, 2023)
No. of Employees	2,522 (as of March 31, 2023)
Fiscal Year End	March 31



## Organization (as of October 1, 2023)

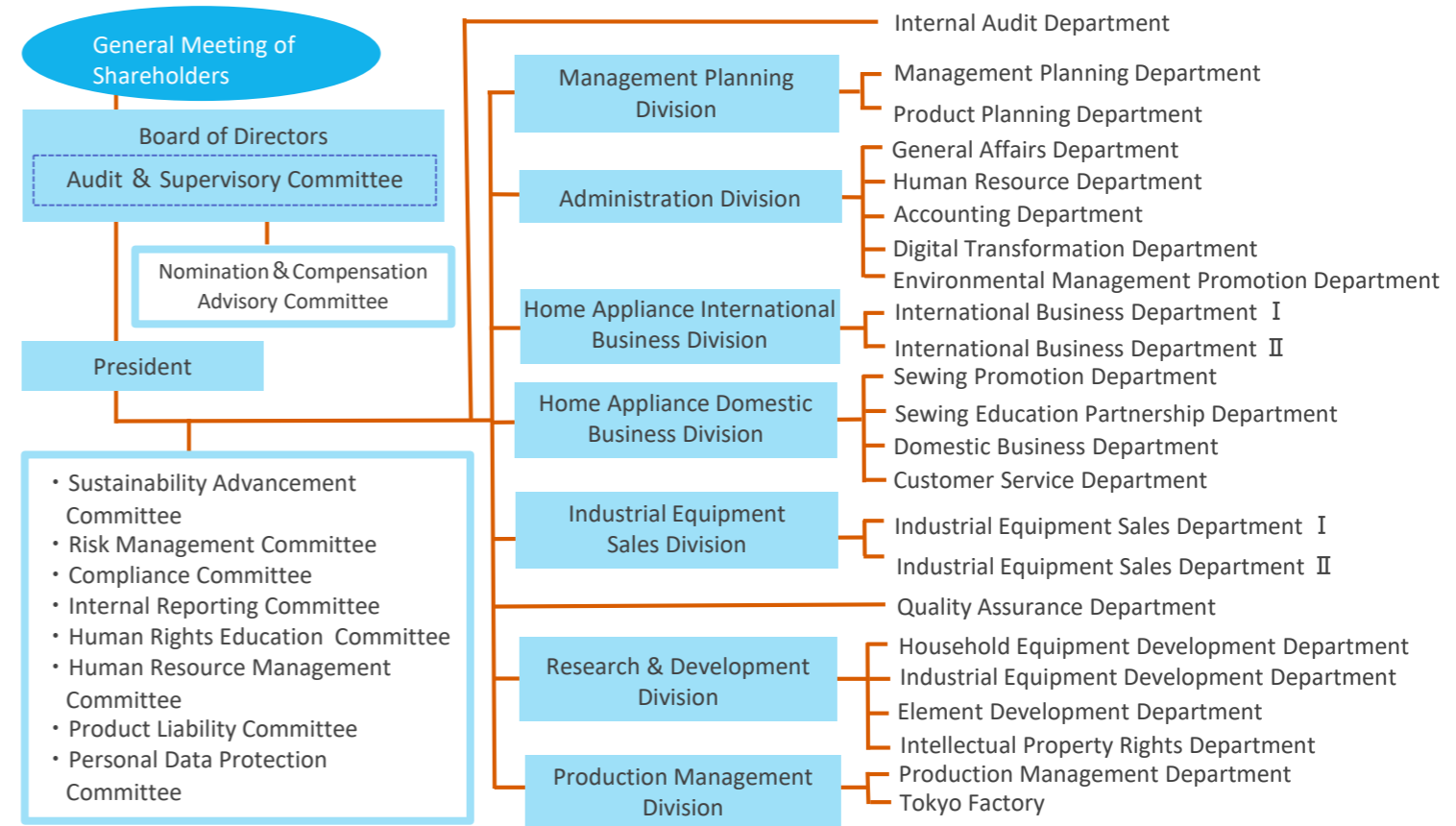

## Stock Information (as of March 31, 2023)

Number of shares issued	19,521,444
Number of shareholders	17,685 (down 1,033 from March 31, 2022)

Shareholder Composition expressed by investment ratio (based on number of shares held)

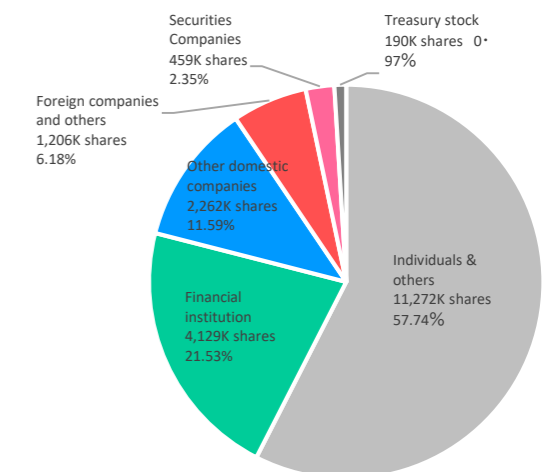

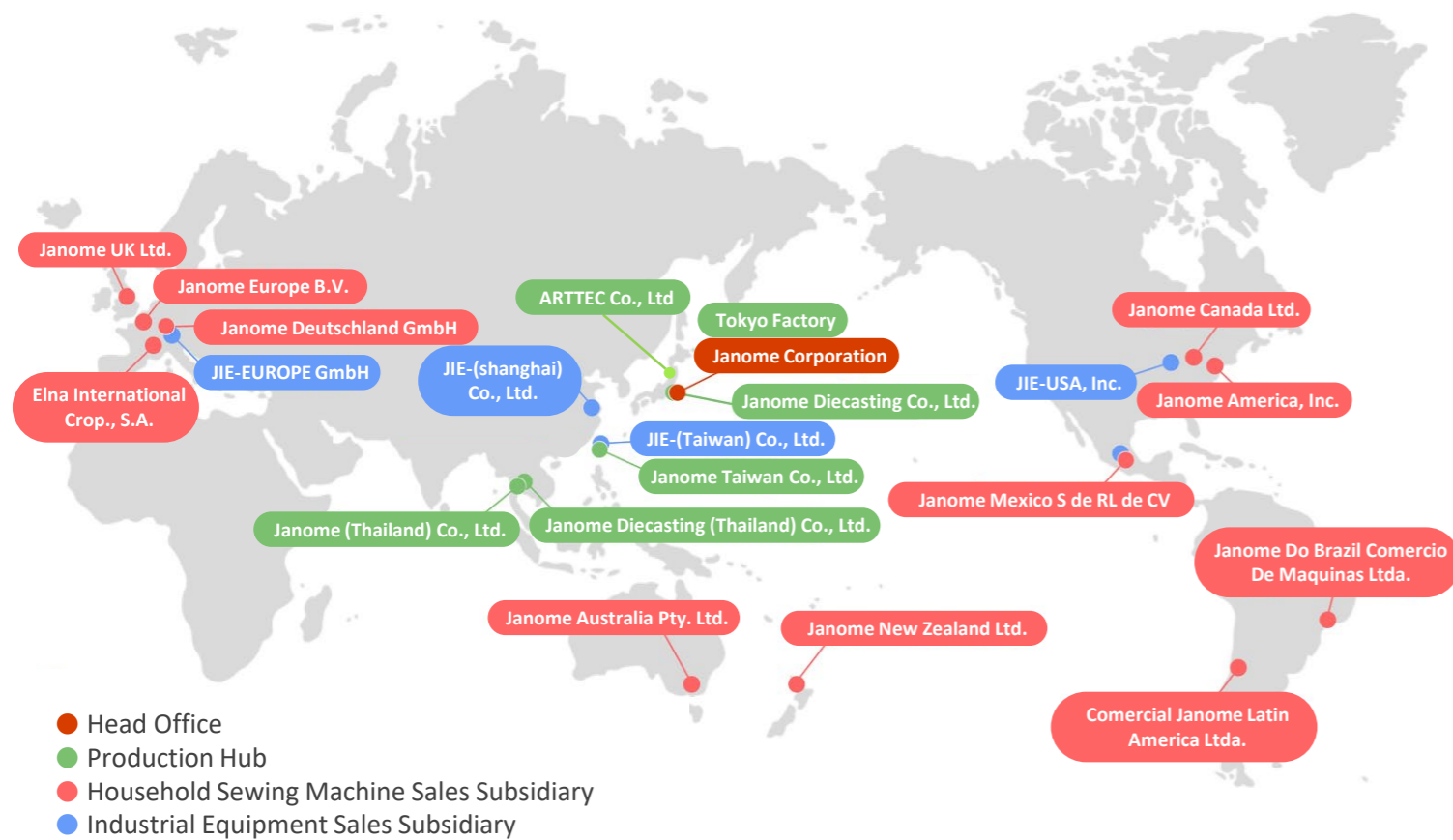

**Production Hubs**

- Tokyo Factory Hachioji, Tokyo
- Janome Taiwan Co., Ltd. Taichung, Taiwan
- Janome Thailand Co., Ltd. Sriracha, Thailand
- Janome Diecasting (Thailand) Co., Ltd. Kabin Buri, Thailand
- JANOME Diecasting Co., Ltd. Tsuru, Yamanashi
- ARTTEC Co., Ltd. Sakata, Yamagata

**Head Office**

- JANOME Corporation Hachioji, Tokyo

**Service Hubs**

- JANOME CREDIA Co., Ltd. Chuo-ku, Tokyo
- JANOME SERVICE Co., Ltd. Hachioji, Tokyo

**Overseas Major Sales Company**

- Janome America, Inc. New Jersey, U.S.A
- Janome Canada Ltd. Ontario, Canada
- Janome UK, Ltd. Stockport, UK
- Janome Europe B.V. Nieuw Venne, The Netherlands
- Janome Deutschland GmbH Mörfelden-Walldorf, Germany
- Janome Australia Pty. Ltd. Cheltenham, Australia
- Janome New Zealand. Ltd. Auckland, New Zealand
- Comercial Janome Latin America Ltda. Santiago, Chile
- Janome Do Brasil Comércio De Máquinas Ltda. Sao Paulo, Brazil
- Elna International Corp., S.A. Geneva, Switzerland
- Janome Mexico S. de R.L. de C.V. Mexico City, Mexico
- JIE USA, Inc. Illinois, U.S.A
- JIE Europe GmbH Bickenbach, Germany
- JIE (Shanghai) Co., Ltd. Shanghai, China
- JIE (Taiwan) Co., Ltd. Hsinchu, Taiwan

※JIE stands for Janome Industrial Equipment

**JANOME**

**JANOME Corporation**  
 〒193-0941 1463 Hazama-machi,  
 Hachioji, Tokyo, Japan  
<https://www7.janome.co.jp/global/>